

#6 *Harmonized Business*
City of Cambridge

MASSACHUSETTS

In City Council

3/8

1982

CD Sullivan moved adjournment

	YEA	NAY	ABSENT	PRESENT
Mr. Daniel J. Clinton	✓			
Mr. Thomas W. Danehy	✓			
Mr. Francis H. Duehay	✓			
Ms. Sandra Graham			✓	
Mr. Leonard J. Russell	✓			
Mr. David E. Sullivan	✓			
Mr. Walter J. Sullivan	✓			
Mr. Wylie	✓		✓	
Mayor Vellucci	✓			

7 0 2

— Moved to be adjourned —

#6
HAPPINESS
BUSINESS

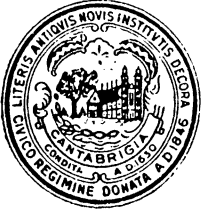

City of Cambridge

In the Year One Thousand, Nine Hundred Eighty-One

AN ORDINANCE

In amendment to an ordinance entitled "The General Ordinances of the City of Cambridge" as revised in 1972 and now designated as "The Code of the City of Cambridge".

Be it ordained by the City Council of the City of Cambridge as follows:

That Chapter Two entitled "Administration", Article XVI entitled "Cambridge Historical Commission" is hereby amended by adding at the end of Section 2-146 the following new paragraph which reads as follows:

There is further established under the provisions of the Historic Districts Act (M.G.L. Ch. 40C) a Fort Washington Historic District consisting of Fort Washington Park and an additional area shown on the map entitled "Fort Washington Historic District, 1981" attached to and made a part of this ordinance.

In City Council March 8, 1982.

Passed to be ordained by a yea and nay vote:- Yeas 7; Nays 0;
Absent 2.

Robert W. Healy, City Manager.

ATTEST:- Paul F. Healy, City Clerk.

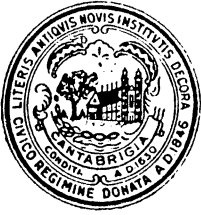

City of Cambridge

In the Year One Thousand, Nine Hundred Eighty-One

AN ORDINANCE

In amendment to an ordinance entitled "The General Ordinances of the City of Cambridge" as revised in 1972 and now designated as "The Code of the City of Cambridge".

Be it ordained by the City Council of the City of Cambridge as follows:

That Chapter Two entitled "Administration", Article XVI entitled "Cambridge Historical Commission" is hereby amended by adding at the end of Section 2-146 the following new paragraph which reads as follows:

There is further established under the provisions of the Historic Districts Act (M.G.L. Ch. 40C) a Fort Washington Historic District consisting of Fort Washington Park and an additional area shown on the map entitled "Fort Washington Historic District, 1981" attached to and made a part of this ordinance.

In City Council March 8, 1982.

Passed to be ordained by a yea and nay vote:- Yeas 7; Nays 0;
Absent 2.

Robert W. Healy, City Manager.

ATTEST:- Paul F. Healy, City Clerk.

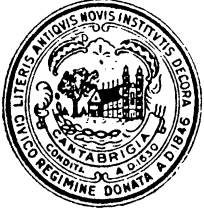

City of Cambridge

In the Year One Thousand, Nine Hundred Eighty-One

AN ORDINANCE

In amendment to an ordinance entitled "The General Ordinances of the City of Cambridge" as revised in 1972 and now designated as "The Code of the City of Cambridge".

Be it ordained by the City Council of the City of Cambridge as follows:

That Chapter Two entitled "Administration", Article XVI entitled "Cambridge Historical Commission" is hereby amended by adding at the end of Section 2-146 the following new paragraph which reads as follows:

There is further established under the provisions of the Historic Districts Act (M.G.L. Ch. 40C) a Fort Washington Historic District consisting of Fort Washington Park and an additional area shown on the map entitled "Fort Washington Historic District, 1981" attached to and made a part of this ordinance.

In City Council March 8, 1982.

Passed to be ordained by a yea and nay vote:- Yeas 7; Nays 0;
Absent 2.

Robert W. Healy, City Manager.

ATTEST:- Paul E. Healy, City Clerk.



City of Cambridge

In the Year One Thousand, Nine Hundred Eighty-One

AN ORDINANCE

In amendment to an ordinance entitled "The General Ordinances of the City of Cambridge" as revised in 1972 and now designated as "The Code of the City of Cambridge".

Be it ordained by the City Council of the City of Cambridge as follows:

That Chapter Two entitled "Administration", Article XVI entitled "Cambridge Historical Commission" is hereby amended by adding at the end of Section 2-146 the following new paragraph which reads as follows:

There is further established under the provisions of the Historic Districts Act (M.G.L. Ch. 40C) a Fort Washington Historic District consisting of Fort Washington Park and an additional area shown on the map entitled "Fort Washington Historic District, 1981" attached to and made a part of this ordinance.

In City Council March 8, 1982.

Passed to be ordained by a yeas and nays vote:- Yeas 7; Nays 0;
Absent 2.

Robert W. Healy, City Manager.

ATTEST:- Paul E. Healy, City Clerk.



City of Cambridge

In the Year One Thousand, Nine Hundred Eighty-One

AN ORDINANCE

In amendment to an ordinance entitled "The General Ordinances of the City of Cambridge" as revised in 1972 and now designated as "The Code of the City of Cambridge".

Be it ordained by the City Council of the City of Cambridge as follows:

That Chapter Two entitled "Administration", Article XVI entitled "Cambridge Historical Commission" is hereby amended by adding at the end of Section 2-146 the following new paragraph which reads as follows:

There is further established under the provisions of the Historic Districts Act (M.G.L. Ch. 40C) a Fort Washington Historic District consisting of Fort Washington Park and an additional area shown on the map entitled "Fort Washington Historic District, 1981" attached to and made a part of this ordinance.

Passed to a second reading at the City Council meeting held on December 28, 1981 and on or after January 18, 1982 the question may come on passing to be ordained.

ATTEST:- Paul E. Healy, City Clerk.

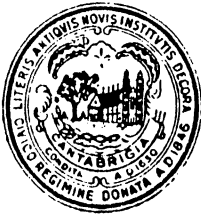

City of Cambridge

In the Year One Thousand, Nine Hundred Eighty-One

AN ORDINANCE

In amendment to an ordinance entitled "The General Ordinances of the City of Cambridge" as revised in 1972 and now designated as "The Code of the City of Cambridge".

Be it ordained by the City Council of the City of Cambridge as follows:

That Chapter Two entitled "Administration", Article XVI entitled "Cambridge Historical Commission" is hereby amended by adding at the end of Section 2-146 the following new paragraph which reads as follows:

There is further established under the provisions of the Historic Districts Act (M.G.L. Ch. 40C) a Fort Washington Historic District consisting of Fort Washington Park and an additional area shown on the map entitled "Fort Washington Historic District, 1981" attached to and made a part of this ordinance.

Passed to a second reading at the City Council meeting held on December 28, 1981 and on or after January 18, 1982 the question may come on passing to be ordained.

ATTEST:- Paul E. Healy, City Clerk.

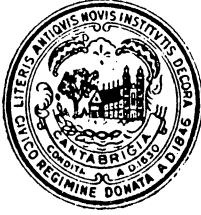

City of Cambridge

In the Year One Thousand, Nine Hundred Eighty-One

AN ORDINANCE

In amendment to an ordinance entitled "The General Ordinances of the City of Cambridge" as revised in 1972 and now designated as "The Code of the City of Cambridge".

Be it ordained by the City Council of the City of Cambridge as follows:

That Chapter Two entitled "Administration", Article XVI entitled "Cambridge Historical Commission" is hereby amended by adding at the end of Section 2-146 the following new paragraph which reads as follows:

There is further established under the provisions of the Historic Districts Act (M.G.L. Ch. 40C) a Fort Washington Historic District consisting of Fort Washington Park and an additional area shown on the map entitled "Fort Washington Historic District, 1981" attached to and made a part of this ordinance.

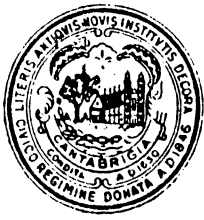

City of Cambridge

In the Year One Thousand, Nine Hundred Eighty-One

AN ORDINANCE

In amendment to an ordinance entitled "The General Ordinances of the City of Cambridge" as revised in 1972 and now designated as "The Code of the City of Cambridge".

Be it ordained by the City Council of the City of Cambridge as follows:

That Chapter Two entitled "Administration", Article XVI entitled "Cambridge Historical Commission" is hereby amended by adding at the end of Section 2-146 the following new paragraph which reads as follows:

There is further established under the provisions of the Historic Districts Act (M.G.L. Ch. 40C) a Fort Washington Historic District consisting of Fort Washington Park and an additional area shown on the map entitled "Fort Washington Historic District, 1981" attached to and made a part of this ordinance.

Passed to a second reading at the City Council meeting held on December 28, 1981 and on or after January 18, 1982 the question may come on passing to be ordained.

ATTEST:- Paul E. Healy, City Clerk.

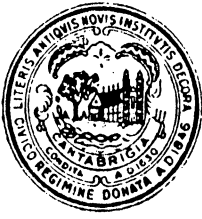

City of Cambridge

In the Year One Thousand, Nine Hundred Eighty-One

AN ORDINANCE

In amendment to an ordinance entitled "The General Ordinances of the City of Cambridge" as revised in 1972 and now designated as "The Code of the City of Cambridge".

Be it ordained by the City Council of the City of Cambridge as follows:

That Chapter Two entitled "Administration", Article XVI entitled "Cambridge Historical Commission" is hereby amended by adding at the end of Section 2-146 the following new paragraph which reads as follows:

There is further established under the provisions of the Historic Districts Act (M.G.L. Ch. 40C) a Fort Washington Historic District consisting of Fort Washington Park and an additional area shown on the map entitled "Fort Washington Historic District, 1981" attached to and made a part of this ordinance.

Passed to a second reading at the City Council meeting held on December 28, 1981 and on or after January 18, 1982 the question may come on passing to be ordained.

ATTEST:- Paul E. Healy, City Clerk.

U

Final Report on the Proposed
Fort Washington Historic District

Cambridge Historical Commission
City Hall Annex; 57 Inman Street
Cambridge, Massachusetts 02139
498-9040 - September 11, 1981
Revised: November 17, 1981



Cambridge Historical Commission

City Hall Annex, 57 Inman Street, Cambridge, Massachusetts, 02139. 617/498-9040



Robert G. Neiley, *Chairman*; William B. King, *Vice Chairman*; Charles M. Sullivan, *Executive Director*.
Dwight H. Andrews; Arthur H. Brooks, Jr.; James F. Clapp, Jr.; Charles W. Eliot, 2d; Joseph G. Sakey; *Commission Members*.
John Lyons, Geneva T. Malenfant, Frances Pierce, *Alternates*.

September 11, 1981

To the Honorable, The City Council:

The Cambridge Historical Commission herewith respectfully submits, pursuant to the Historic Districts Act (Massachusetts General Laws, Chapter 40C) and the Cambridge Historical Commission Ordinance, its Final Report on the Proposed Fort Washington Historic District. This report contains for your consideration an amendment to the City Code establishing such a district, a proposal which has been endorsed by the Cambridge Historical Commission, the Massachusetts Historical Commission and the Cambridge Planning Board.

Sincerely yours,

Robert G. Neiley
Chairman

RGN/pb

TABLE OF CONTENTS

SUMMARY

- I. The Proposed Fort Washington Historic District
- II. The Nature of Historic District Protection
- III. Administration of Existing and Proposed Historic Districts in Cambridge

APPENDIX

- A. Proposed Amendment to the City Code Establishing the Fort Washington Historic District

Martin Annis
President

American Science and Engineering, Inc.
955 Massachusetts Avenue
Cambridge, Massachusetts 02139
617 868-1600

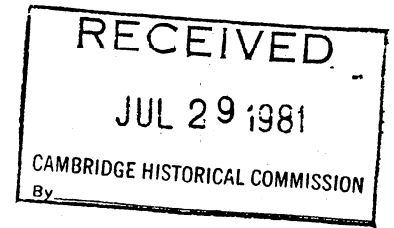

July 29, 1981

Charles M. Sullivan, Executive Director
Cambridge Historical Commission
City Hall Annex
57 Inman Street
Cambridge, MA 02139

Re: Proposed Fort Washington Historic District

Dear Mr. Sullivan:

Some time ago you had written to us concerning the proposal that a Fort Washington historic district be established. We have reviewed a copy of your preliminary report on that proposal and we have been notified of the Public Hearing to be held on July 30th concerning the matter.

We are writing at this time to indicate our agreement with the proposal as outlined in your preliminary report and with the goal of ensuring a proper setting for historic Fort Washington. As you know, we at AS&E have made every attempt to take the importance of this historic site into account in the planning and design of our renovation to the St. Johnsbury building.

Please register our support for your proposal at the Hearing to be held this coming Thursday and we will be grateful if you will keep us apprised of the progress of your proposal.

Warmest regards,

A handwritten signature in cursive script that reads "Martin Annis".

MA/mbj



CITY OF CAMBRIDGE, MASSACHUSETTS
PLANNING BOARD

CITY HALL ANNEX, 57 INMAN STREET, CAMBRIDGE 02139

June 11, 1981

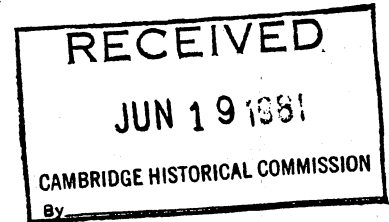

Mr. Charles Sullivan, Executive Director
Cambridge Historic Commission
City Hall Annex
57 Inman Street
Cambridge, MA 02139

Dear Mr. Sullivan:

The Planning Board of the City of Cambridge has received and considered a document entitled "Preliminary Report on the Proposed Fort Washington Historic District" as required by Chapter 40C of the Massachusetts General Law.

The Planning Board strongly endorses the establishment of the Fort Washington Historic District as outlined in the above referenced document. Such a district would be consistent with the best interests of both the City as a whole and the Cambridgeport neighborhood within which it is located.

After a two year comprehensive review and analysis of the future development needs of the Cambridgeport Industrial District, the Planning Board has recommended to the City Council that as part of a complete rezoning of the area, a special zoning district be established around Fort Washington.

Coterminus with the recommended historic district boundaries, this special zoning district is intended, within the limited authority of the zoning enabling statutes, to achieve the same objectives as the historic district, namely to ensure that any future development in the vicinity of Fort Washington is compatible with and enhances the park's historic and aesthetic values.

A special zoning district is an important means of protecting the park; historic designation however will more completely ensure the park's long-term protection.

Respectfully submitted
for the Planning Board,

Arthur C. Parris

Arthur C. Parris
Chairman

ACP:sl



**MASSACHUSETTS
HISTORICAL
COMMISSION**

**COMMONWEALTH OF MASSACHUSETTS
Office of the Secretary of State**

294 Washington Street
Boston, Massachusetts
02108
617-727-8470

MICHAEL JOSEPH CONNOLLY
Secretary of State

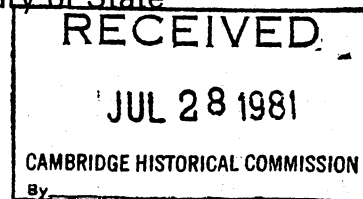

July 23, 1981

Charles Sullivan, Executive Director
Historic District Study Committee
Cambridge Historical Commission
City Hall Annex
57 Inman Street
Cambridge, Massachusetts 02139

Dear Mr. Sullivan:

On June 10, 1981, the Massachusetts Historical Commission endorsed the proposed Fourt Washington historic district in Cambridge. As you probably know, ~~such an endorsement must be followed by town meeting approval~~ and subsequent notification of the Massachusetts Historical Commission office for an area to become a local historic district.

The Massachusetts Historical Commission is most curious about the current status of the historic district study within your community. It would be most appreciated if you could complete and return the enclosed form as soon as possible so that we may know how your work is going. Thank you for your time and consideration in this matter.

Please do not hesitate to call if we can be of any assistance.

Sincerely,

Judith S. Kessler
Program Assistant
Massachusetts Historical Commission

JSL/dmi
encl.

I. The Proposed Fort Washington Historic District

The proposed Fort Washington Historic District includes the 0.97 acre park of that name plus an additional area within 100 feet of the park boundaries on the north, south and west and fifty feet on the east. Also on the east, a corridor 50 feet wide extends to Vassar Street, 25 feet to each side of the center axis of the park. The total area of the district is 3.47 acres. This protective zone includes portions of vacant lots on the north, south and east of the park, part of the former truck terminal of the St. Johnsbury Trucking Company, and railroad rights-of-way occupied by the Consolidated Rail Corporation (Conrail) and the Stimpson Terminal Company. This area is now the focus of considerable development plans, and the purpose of the proposed district is to protect the park and its environs from inappropriate future development. No existing buildings are located within the district, but future construction will be guided to protect the light, air, and architectural surroundings of the park, and to maintain a sense of the former "field of fire" to the river. The proposed district will at no time regulate the use of existing or future buildings surrounding the park.

A. Historical Brief

Fort Washington, now a public park on Waverly Street in an industrial area of Cambridgeport, was erected at the direction of General Washington during the Siege of Boston. One of several forts erected by the Continental Army at the time, it is now the only fortification from the Siege of Boston still retaining its original earthworks. It was recorded by the Historic American Building Survey of the National Park Service in 1934, and was placed on the National Register of Historic Places in 1970.

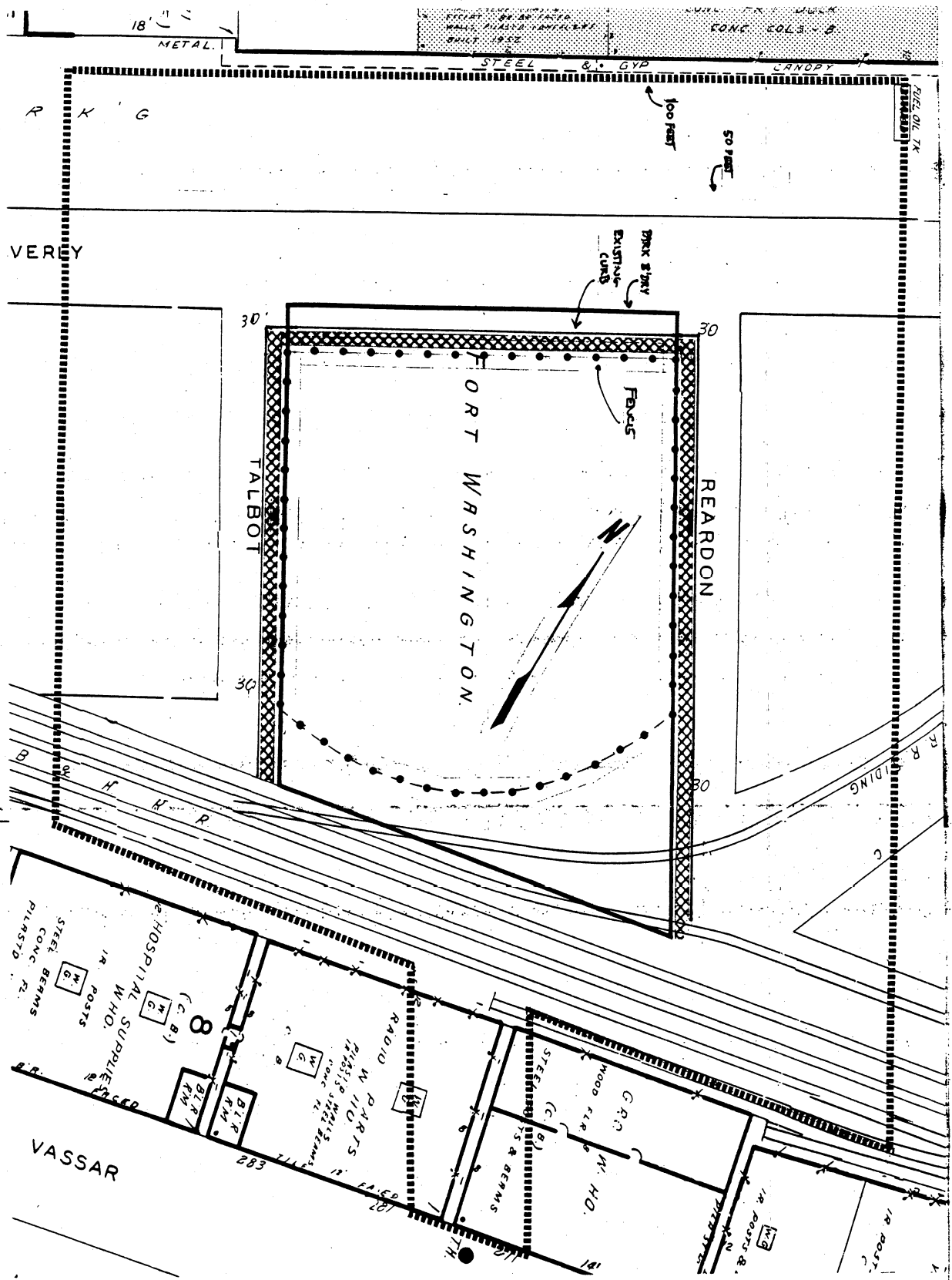

Proposed Fort Washington Historic District

- ● ● ● ● fence line
- ▨ sidewalk
- curb (installed 1978)
- park boundary
- ▬ historic district boundary

Cambridge Historical Commission
September 11, 1981

With the **MILITARY WORKS** Constructed in those Places in the Years 1775 and 1776.

1st August
 we have the Excellency
 in person to take
 a view of the places in this
 town & Charlestown and
 to be directed or impeded
 by a report & a from the above
 the heights of Charlestown
 for completing this said
 views of the things
 Ja. Vigniant
 Town Major

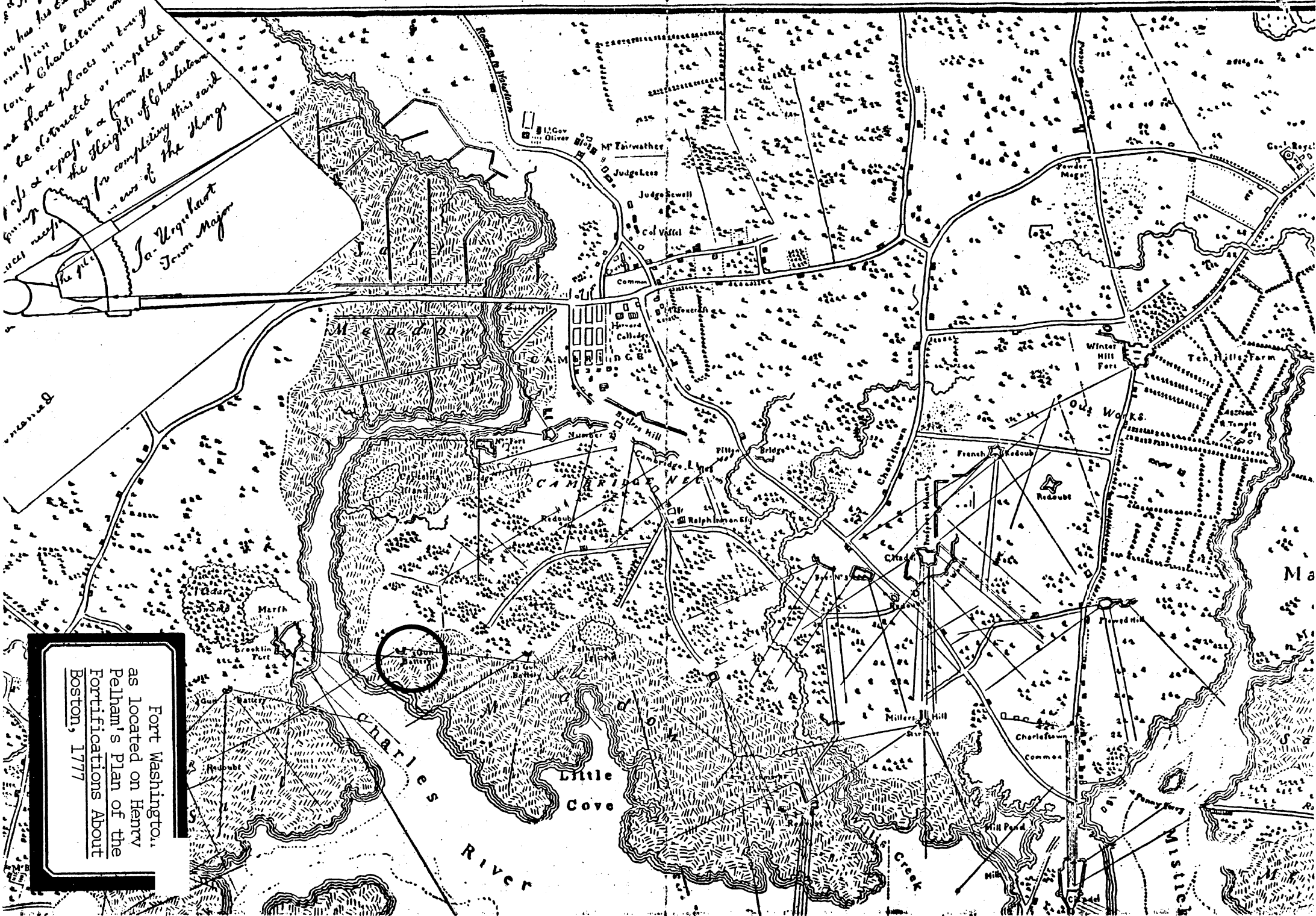

Fort Washington,
 as located on Henry
 Pelham's Plan of the
 Fortifications About
 Boston, 1777

After the Battles of Concord and Lexington and Bunker Hill, the British retreated to Boston and Washington determined to encircle the town with fortifications. In his report to the Continental Congress on November 28, 1775, Washington wrote:

I have caused two half-moon batteries to be thrown up, for occasional use, between Lechmere's Point and the mouth of Cambridge River, and another work at the Causey [causeway] going to Lechmere's Point, to command that pass, and rake the little rivulet that runs by it to Patterson's Fort. Besides these, I have ... marked out three places between Sewall's Point and our lines on Roxbury Neck, for works to be thrown up, and occasionally manned, in case of a sortie when the bay gets froze.

At the time Fort Washington was erected, it stood on the edge of the Charles River overlooking the Back Bay (then an open body of water) and the Boston Neck, and was surrounded on three sides by marsh and water. It consisted of an embankment in the form of a half-circle 120 feet in diameter, with openings for three light field pieces and a water-filled ditch in front from which the earth was excavated. There is no record that the fort participated in an engagement.

For sixty years after the Revolution, the fortifications lay abandoned in the marshes on the Charles, well apart from the settled parts of Cambridge and facing the unfilled flats of Boston's Back Bay. The development of turnpikes and bridges between Cambridge and Boston left the area untouched, and most of the peninsula below Central Square remained undeveloped and in the hands of the Dana family until the 1850s. In 1838, the family hired Alexander Wadsworth, surveyor of Mount Auburn Cemetery, to lay out a residential subdivision to be known as Pine Grove. Wadsworth's plan for the fort envisioned an oval

WAVERLY ST.

30.

30.

TALBOT STREET

STREET

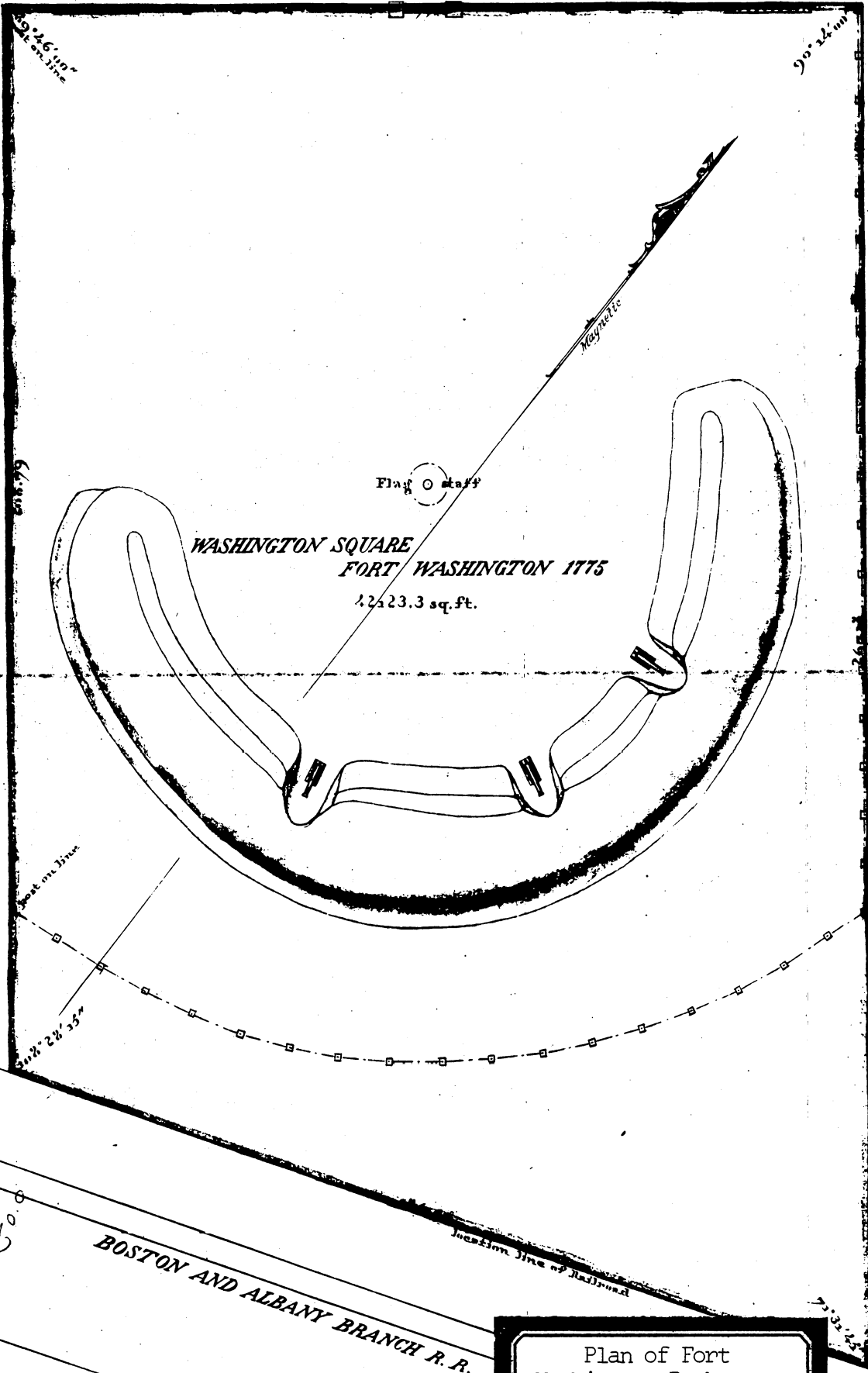

Plan of Fort Washington Park, c.1860. Office of the Cambridge City Engineer.

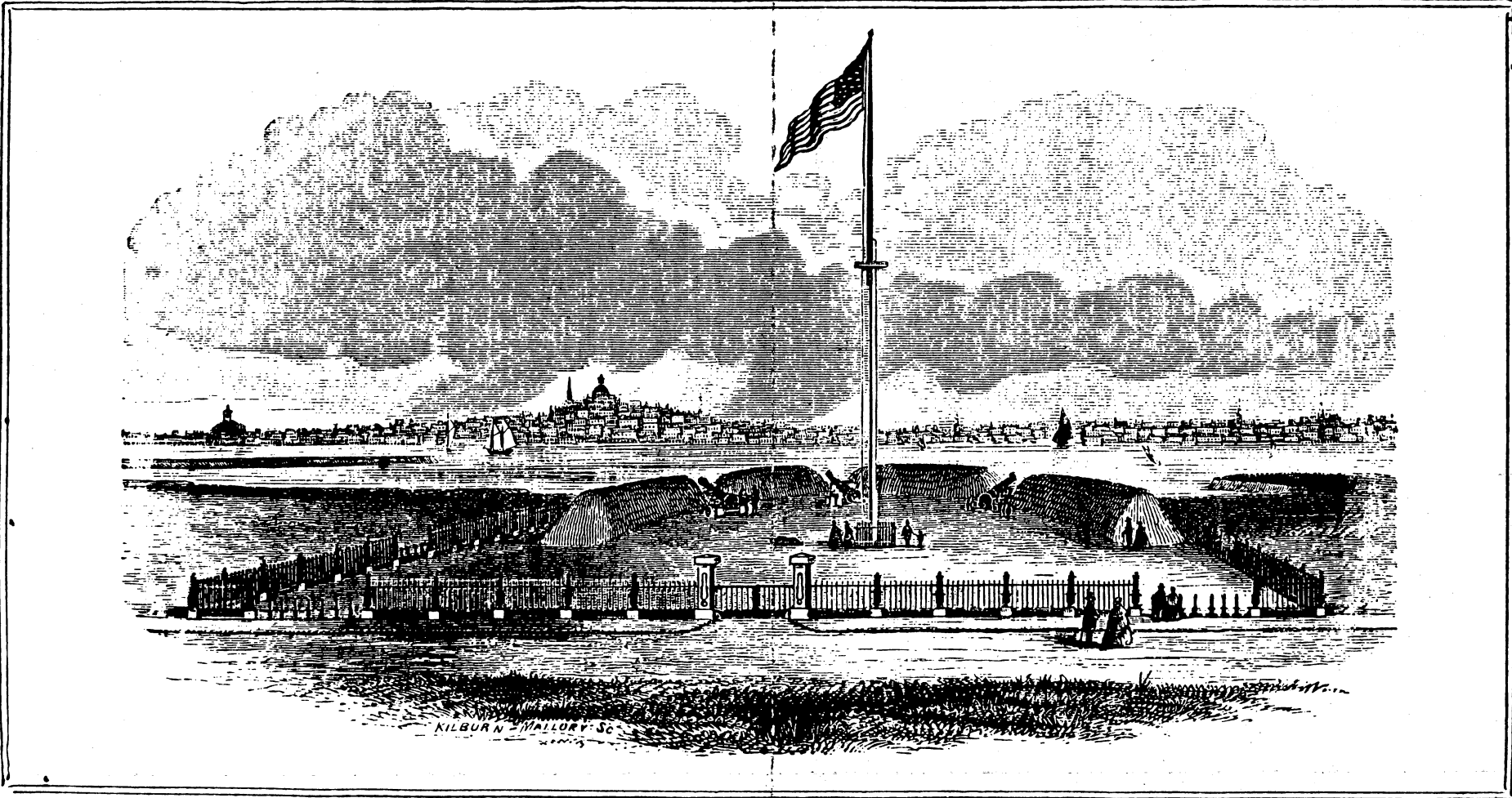

Fort Washington
in 1861

park to be known as Washington Square, bounded on three sides by lots subject to severe restrictions against "nauseous or offensive trades."

Pine Grove was not a success, however, and only two or three houses were built facing the park. In 1856 the Grand Junction Railroad built an embankment between the fort and the river, cutting off a corner of Washington Square, and in 1857 the Square was conveyed to the City by the Dana heirs to protect it against further incursions. The Commonwealth appropriated \$2,000. to improve the site, and the Secretaries of War and Navy provided the cannon and carriages presently located in the earthworks. The fence, and presumably the planting, was designed by John R. Hall, a Boston architect about whom nothing further is known, and cast by Joel Robinson of Cambridge for \$3,350. The plan, which is illustrated, shows the arrangement of the fence and entrances which existed until 1966. The only feature other than the earthworks and cannon was a flagpole.

The continuing industrialization of the park's surroundings led to neglect and deterioration, and by 1900 the neighborhood was known as "greasey village" for the adjacent soap works. In 1903 the park was restored by the City at the urging of the local chapter of the Daughters of the American Revolution. The park was well documented at that time and these drawings and photographs provided the basis of the 1976 restoration.



Rededication of
Fort Washington, 1903.
M.I.T. Historical
Collections.

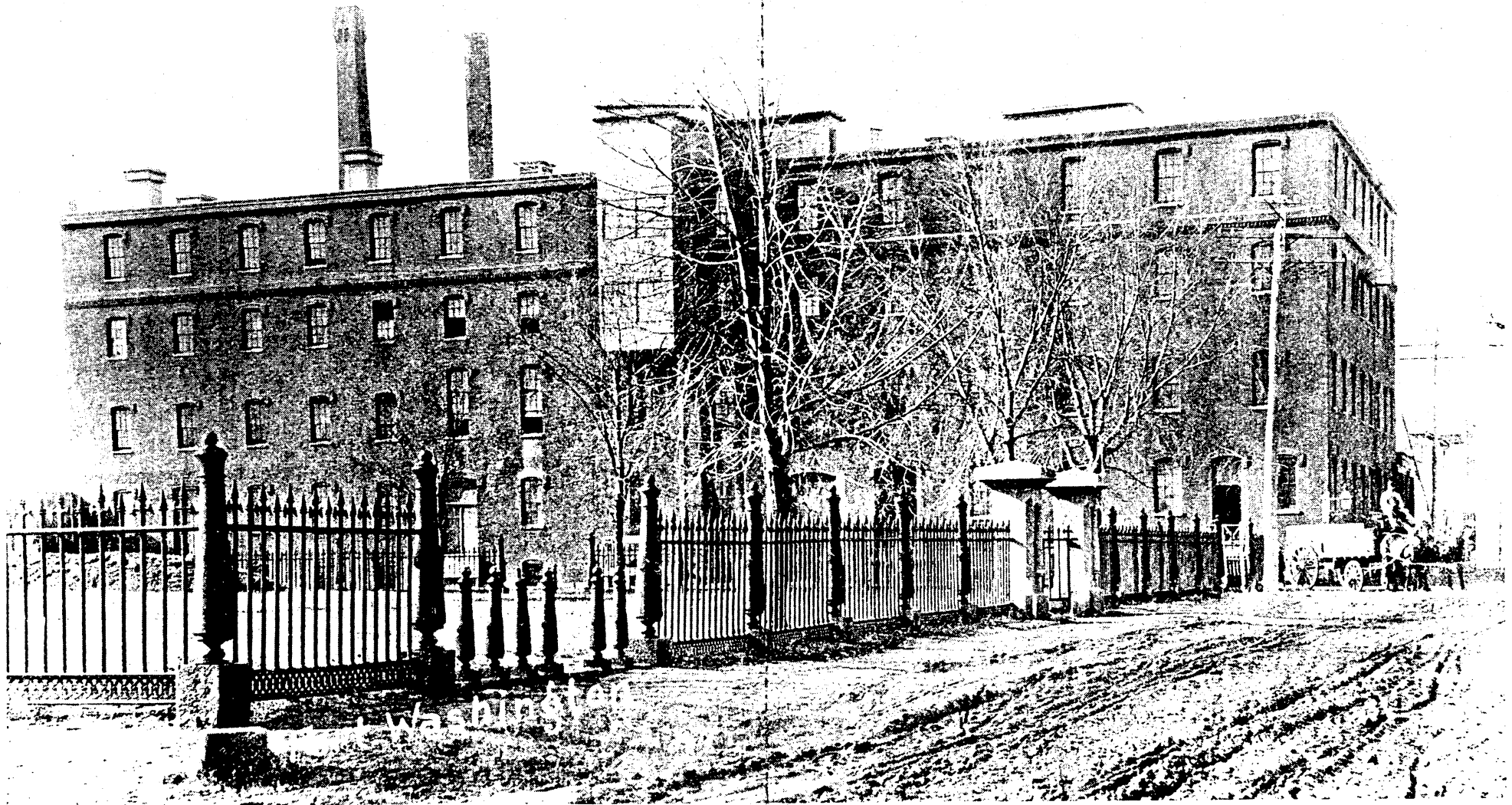

Fort Washington
in 1878.

Cambridge Historical
Commission

The deterioration of the park accelerated after the St. Johnsbury Trucking Company located in the area during the 1940s. Factories on Reardon and Talbot Streets were demolished and paving was laid up to the park fence, without protective curbing. Allston Street - which had given the Cambridgeport community direct access to the park - was closed to permit construction of a trucking terminal. At some point, a portion of the park land along the railroad tracks was illegally paved, so that the park was completely ringed with streets and parking lots used by tractor-trailers. Lack of adequate maneuvering room meant that the fence was continually struck by trucks, and a misguided restoration in 1966 only hastened its deterioration. By 1975, no section of ~~the fence remained intact and the earthworks were eroding~~ badly. Only the efforts of Professor Douglas Adams of M.I.T. and others kept the condition of the Fort before the public eye.

B. Restoration of the Park

The current appearance of Fort Washington Park is the result of an extensive restoration project initiated at the urging of Professor Adams and carried out by the Cambridge Historical Commission between 1976 and 1978. The purpose of the restoration was to recapture the historical appearance of the park as developed in 1857 and to provide physical protection against encroachment by the incompatible activities which surround it. The establishment of a Fort Washington Historic District will provide further protection through statutory regulation.

The restoration of the park focussed on three areas: perimeter security, the restoration of the fence, and landscaping.



Fort Washington in 1975,
showing deterioration of
fence.

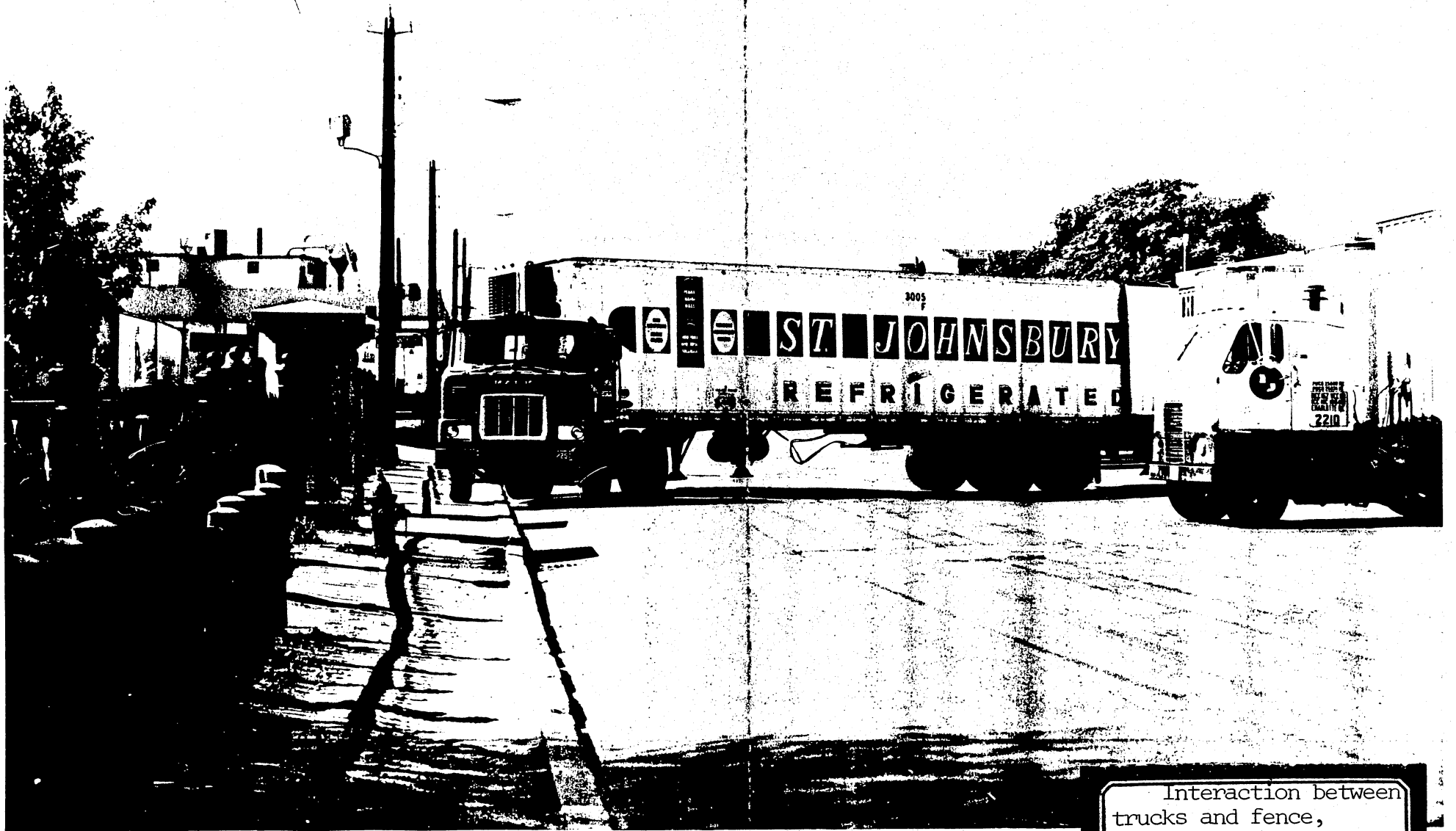

Typical traffic conditions on Waverly Street. Note the use of the sidewalk by the truck, and the appearance of the cement-filled steel pipe bollards at the extreme left.

Interaction between
trucks and fence,
Waverly Street,
September, 1975
Cambridge Historical
Commission Photo.

The restoration plan was based on the documented appearance of the park after its previous restoration in 1903, supplemented by an 1866 view, by drawings of the Historic American Buildings Survey, an archeological field survey, and field observation.

The need for perimeter security was dictated by the continual incursions of trucks, not by the need to restrict pedestrian access. Because the record of municipal maintenance of the park is poor, any restoration would have to be as nearly maintenance-free as possible, especially since no additional capital funds could be expected to repair future damage to the fence. Construction of a barrier that would be proof against damage by heavy trucks was considered an essential part of the project, but the narrowness of Waverly Street and the use by St. Johnsbury of a back-in loading operation meant that a barrier on that side would either be so high and sturdy as to obscure the fence or so far into the street as to deny St. Johnsbury the use of the public way. Accordingly, it was decided to relocate the fence of two sections, or 20' 10", away from Waverly Street. This allowed the use of an unobtrusive perimeter barrier of 10" by 10" timber bollards six feet away from the fence, as well as a new sidewalk ten feet wide, a higher-than-normal granite curbing, and a paving strip of granite setts laid in concrete. Six foot wide sidewalks with new curbing and bollards were also installed along Talbot and Reardon Streets where none had existed before, while access to the rear of the park was blocked and the paving removed.

The condition of the fence was ruinous when restoration began; it was found that not a single panel existed with all original components intact. The 1966 restoration had destroyed much original material and caused additional deterioration of the remaining parts. Because of these conditions and the need to relocate the Waverly Street fence, and because changed grades in the area had brought the new sidewalk grades to as much as 18" above the bottom rail of the original fence, it was decided to dismantle the original fence, relocate the stone gate posts, and reset the granite bases to match the new grade. Of all the original components, only the cannon posts could be reused; all top and bottom rails and pickets were cast from patterns made to duplicate the originals.

~~All traces of the miniature cannon at the pedestrian entrances~~
had disappeared and these sections had been filled in with fencing; these cannon were cast from patterns made from the HABS drawings of 1934, and the original granite sills were found buried under asphalt. Budget constraints dictated that only the Waverly Street fence and gates and several panels on Talbot and Reardon Streets could be restored. The remaining sections of the original fence were left in place, and the original granite bases uncovered.

Landscaping of the site mainly focussed on protecting the earthworks from further deterioration. An archeological survey made in 1975 determined that the earthworks dated from the 18th century, and consisted of a core of highly organic marsh soil under a later layer of gravel and topsoil. This protective layer had been eroded along the tops of the mounds,

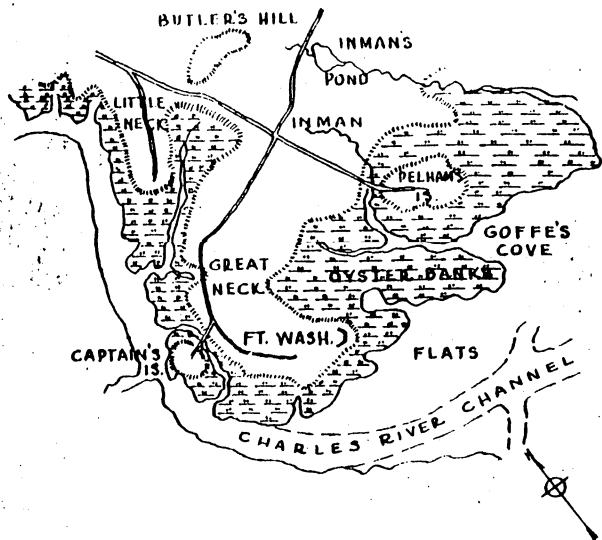

TAKEN FROM A MAP COMPILED TO SHOW THE PAROLE LIMITS OF BURGOYNE'S OFFICERS IN 1777.

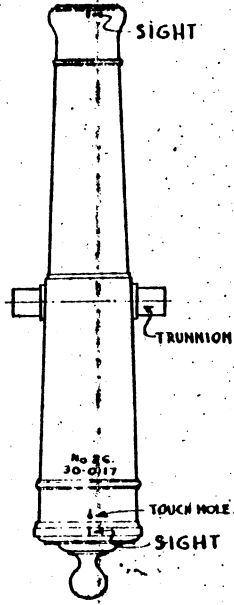

CANNON PLAN

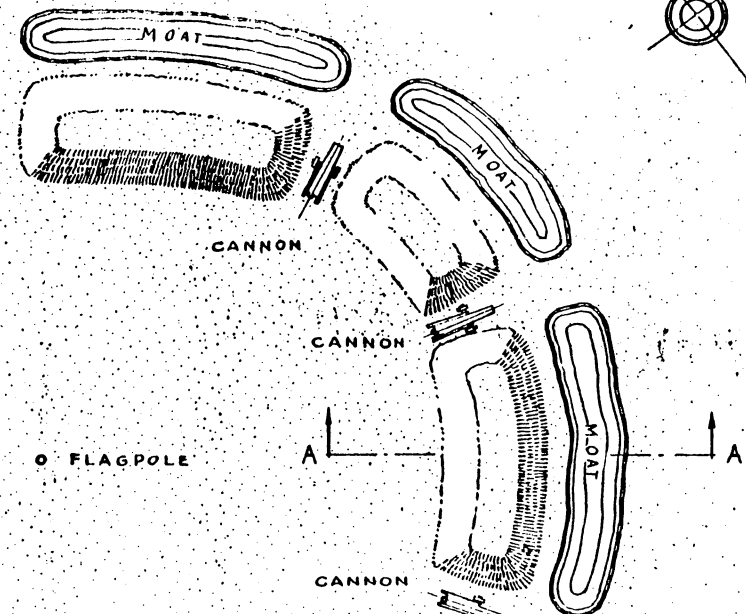

PLAN OF FORT

DETAILS OF CANNON AND CARRIAGE

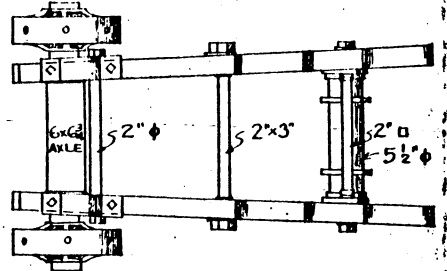

PLAN OF GUN CARRIAGE

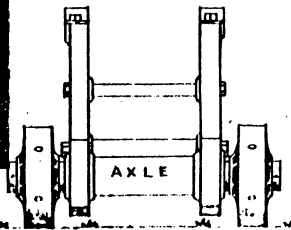

FRONT ELEVATION

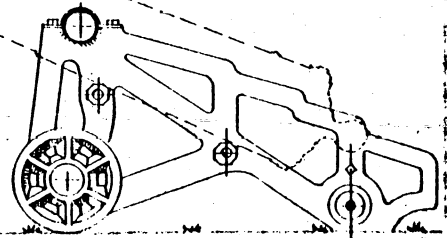

SIDE ELEVATION



SECTION "A-A"

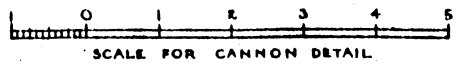

SCALE FOR CANNON DETAIL

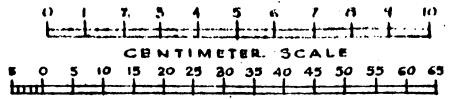

SCALE OF FEET FOR FORT

Historic American Building Survey, 1934

JOHN LATIMER TURNER DEL.

BUILT IN 1775

U.S. DEPARTMENT OF THE INTERIOR
OFFICE OF NATIONAL PARKS, BUILDINGS, AND RESERVATIONS
BRANCH OF PLANS AND DESIGN

NAME OF STRUCTURE
FORT WASHINGTON · CAMBRIDGE · MIDDLESEX CO · MASS.

SURVEY NO.
2-48

HISTORIC AMERICAN BUILDINGS SURVEY
SHEET 1 OF 3 SHEETS

INDEX NO.

Historic American Building Survey, 1934

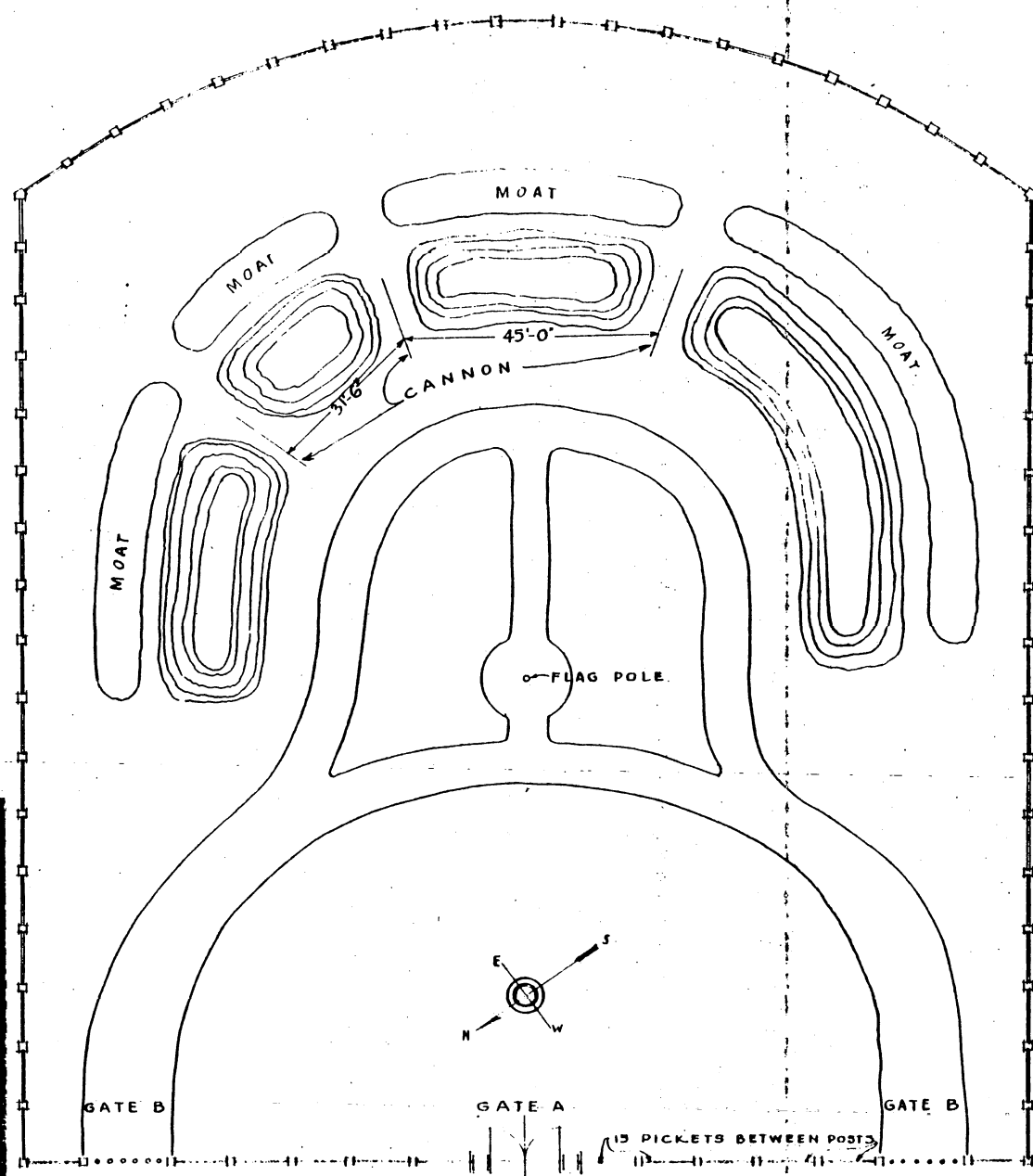

PLAN OF PARK

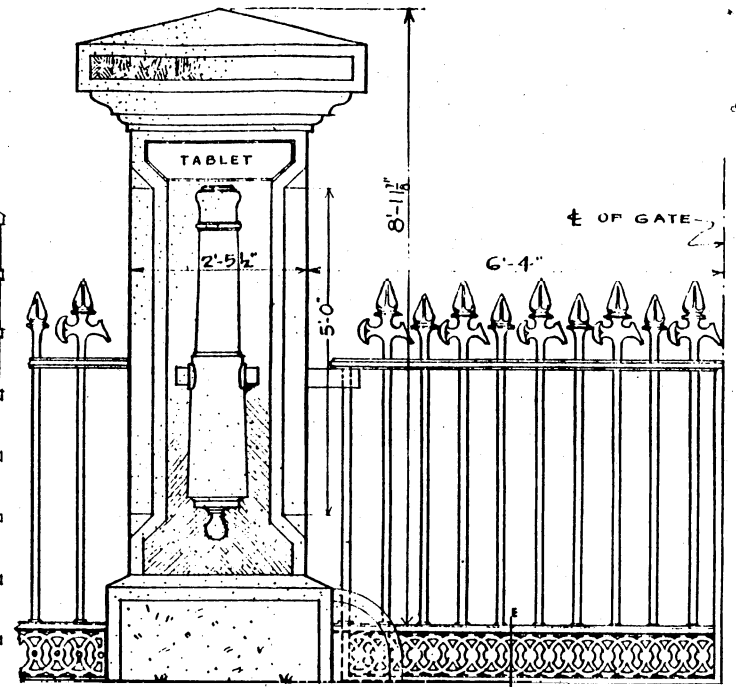

GATE AND GATE POST ELEVATION

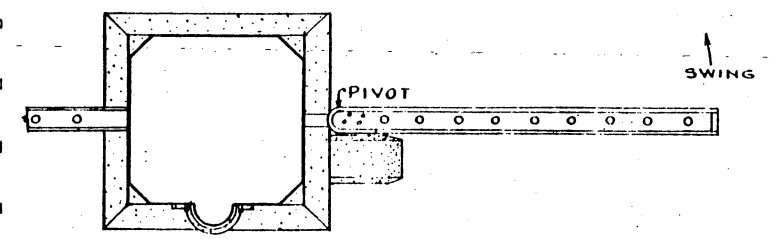

PLAN

^ INSCRIPTION ON TABLET ^
 "FORT WASHINGTON
 CONSTRUCTED NOVEMBER 1775 BY THE
 CONTINENTAL ARMY UNDER
 GENERAL GEORGE WASHINGTON"

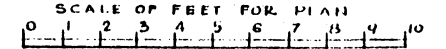
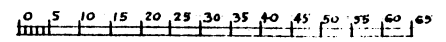

CENTIMETER SCALE

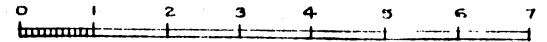

FOOT SCALE FOR DETAILS

JOHN LATIMER. TURNER. DEL.

DATE OF FENCE AND PARK 1858

U.S. DEPARTMENT OF THE INTERIOR
 OFFICE OF NATIONAL PARKS, BUILDINGS, AND RESERVATIONS
 BRANCH OF PLANS AND DESIGN

NAME OF STRUCTURE
 IRON WORK - FORT WASHINGTON PARK - CAMBRIDGE - MIDDLESEX CO. MASS.

SURVEY NO.
 2-48

HISTORIC AMERICAN BUILDINGS SURVEY
 SHEET 2 OF 3 SHEETS

INDEX NO.

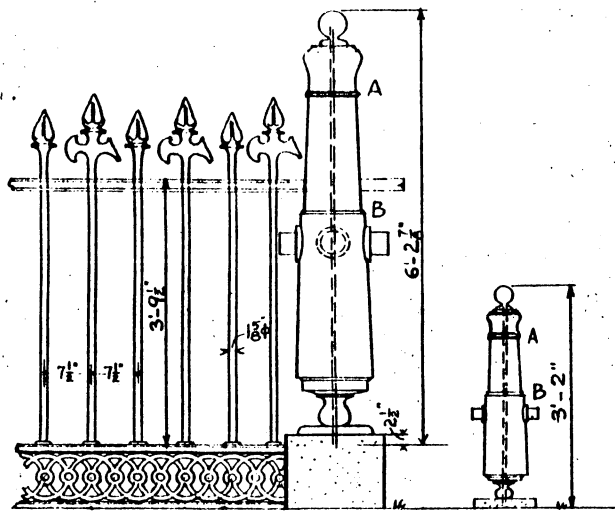

PICKETS AND TYPICAL POST
INTERMEDIATE POST AT GATE B

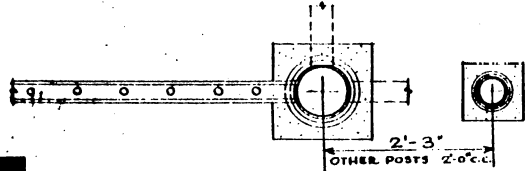

PLAN

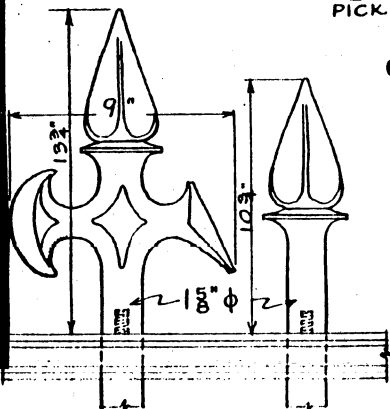

PICKET DETAILS
PICKET HEADS SCREW IN PLACE

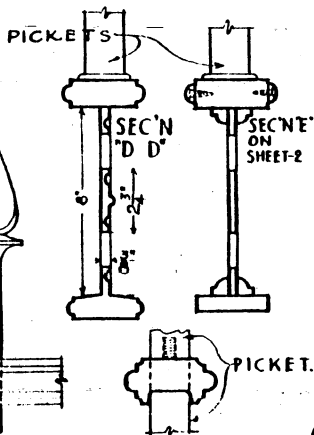

RAIL

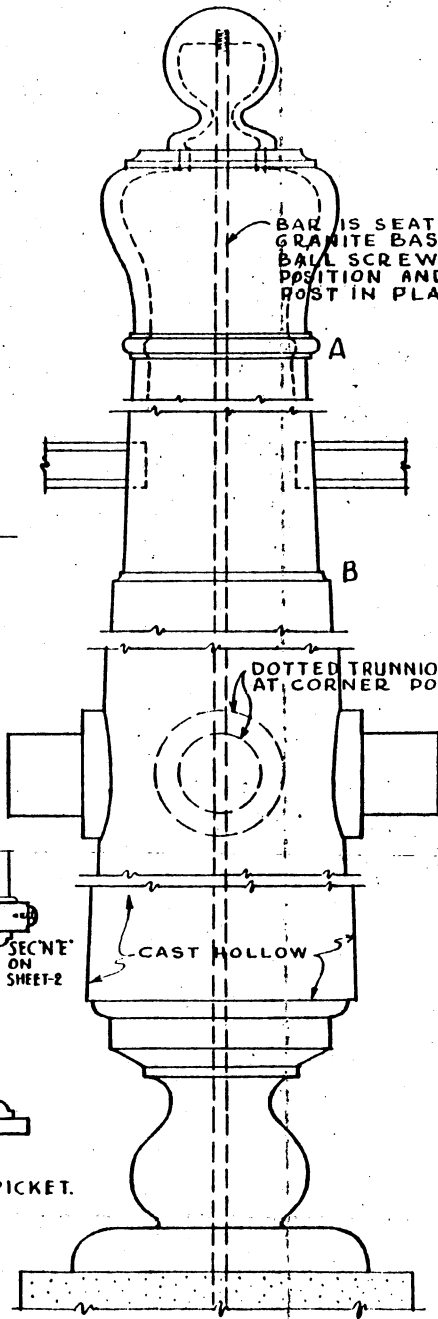

DETAIL TYPICAL POST

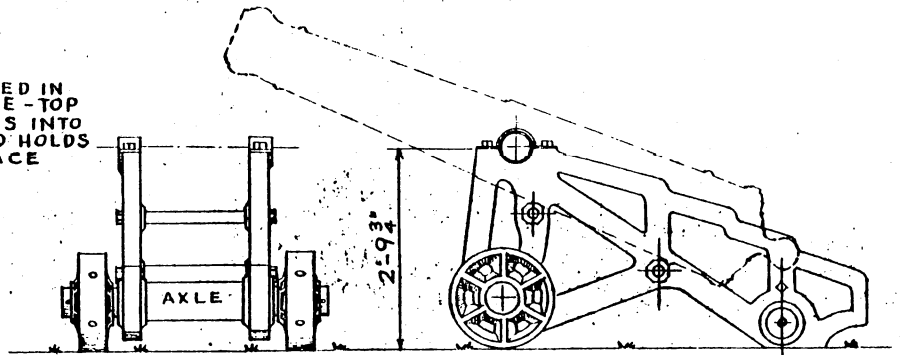

FRONT ELEVATION SIDE ELEVATION

GUN CARRIAGE

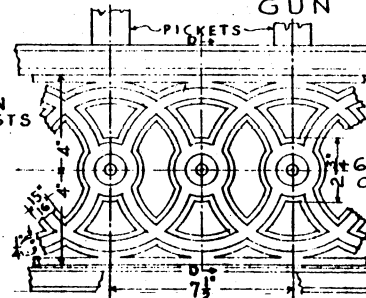

BOTTOM OF FENCE.
(CAST-IRON)-

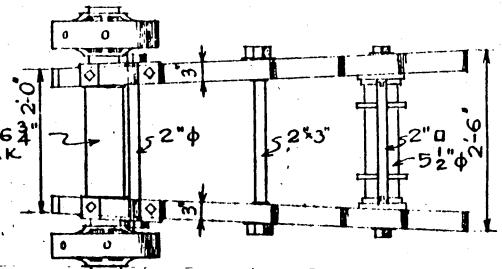

PLAN OF GUN CARRIAGE



MOUTH

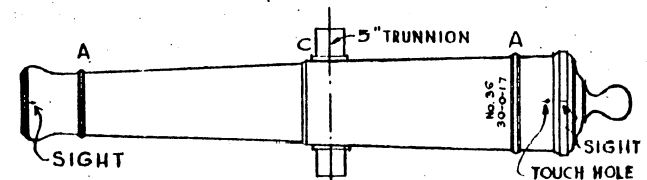

PLAN OF CANNON

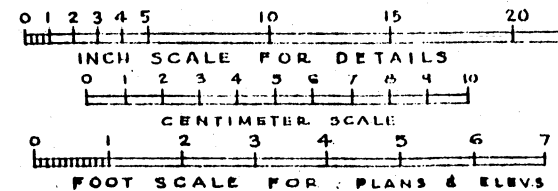

JOHN LATIMID. TURNER. D.M.L.

DATE OF FENCE AND PARK 1858

NAME OF STRUCTURE

U.S. DEPARTMENT OF THE INTERIOR
OFFICE OF NATIONAL PARKS, BUILDINGS, AND RESERVATIONS
BRANCH OF PLANS AND DESIGN

IRON WORK - FORT WASHINGTON PARK - CAMBRIDGE - MIDDLESEX CO. MASS.

SURVEY NO.
2-48

HISTORIC AMERICAN
BUILDINGS SURVEY
SHEET 3 OF 3 SHEETS

INDEX NO

Historic American
Building Survey, 1934

coming dangerously close to exposing the original core to erosion. These areas were regraded and seeded, and the park's original large elms, which succumbed to disease during the project, were completely replaced by disease-resistant Japanese elms. Finally, the formerly paved areas were also graded and seeded, increasing the landscaped area of the park by twenty per cent.

The first stage of the restoration was completed in 1978. The barrier of timber bollards has been successful in protecting the fence from damage, although some of the bollards themselves have been damaged. The restored fence appears to be standing up to the weather successfully and the longterm prospects of the park appear to be good, although completion of the restoration is not envisioned in the foreseeable future because of the lack of funds for such projects.

C. The Need for Statutory Protection

Fort Washington exists as the sole public open-space within the large industrial and commercial district west of the Conrail tracks and between Massachusetts Avenue and the Charles River. It is an isolated location, separated from M.I.T. and the Charles River by the railroad tracks and the warehouses along Vassar Street and from the residential community by the St. Johnsbury terminal across the former line of Allston Street. It is further isolated from the community at large by a confused street pattern. It has no resident user population and lies on no present through pedestrian or vehicular route.

The vulnerability of the park to deterioration in the

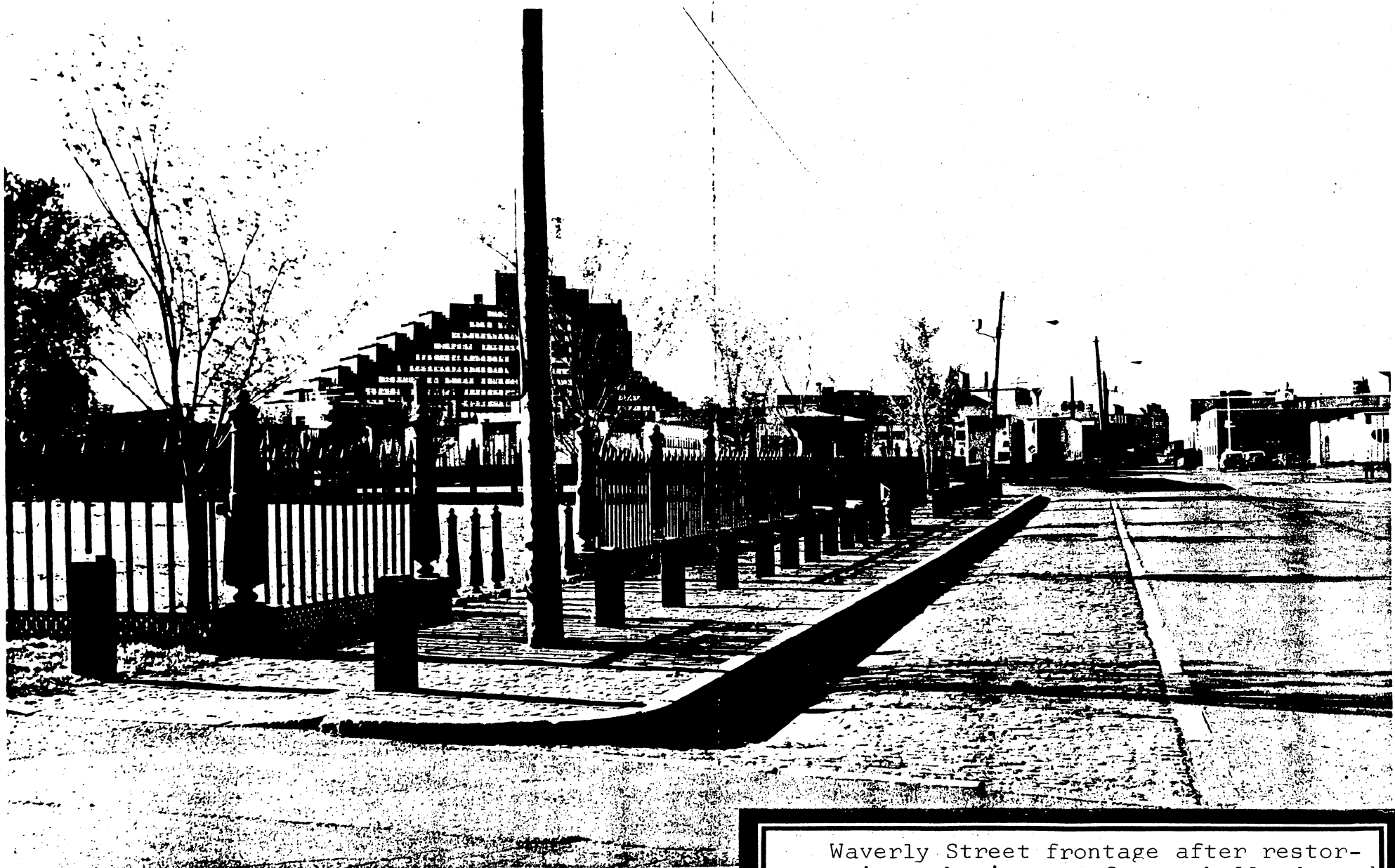

Waverly Street frontage after restoration, showing new fence; bollards and relocated utilities; new 9" curb and brick sidewalk; and granite paving. October, 1978

past was due to its isolation and industrial surroundings, and the recent restoration project was intended to secure the park against a hostile environment for many years to come. Prospects for a change in the setting of the park are now greater than they have been in recent history, due to the departure of the St. Johnsbury Company and the sale of their property to American Science & Engineering, Inc. (AS&E), for an office headquarters and light manufacturing facility. At the same time, the Massachusetts Institute of Technology, owner of vacant lots facing the park on Reardon and Talbot Streets, has begun to study the possibilities of new development on these parcels. Finally, AS&E has pressed for pedestrian access across the railroad tracks to the River, holding out the prospect of generating park visitors from the Hyatt Regency Hotel as well as from the community.

The objectives of the Historical Commission for the redevelopment of the Fort Washington area are to promote development of the surrounding vacant lots with structures that will create an appropriate urban setting for this former residential square; to retain an open "field of fire" toward the River and Boston, recalling the original military purpose of the fort; and to develop a resident user population for the park, whether through residential users on the surrounding properties or through improved pedestrian connections with the rest of Cambridgeport.

The historic district proposed by the Commission will promote these objectives without restricting development of the area. The district will include the 0.97 acre park, plus

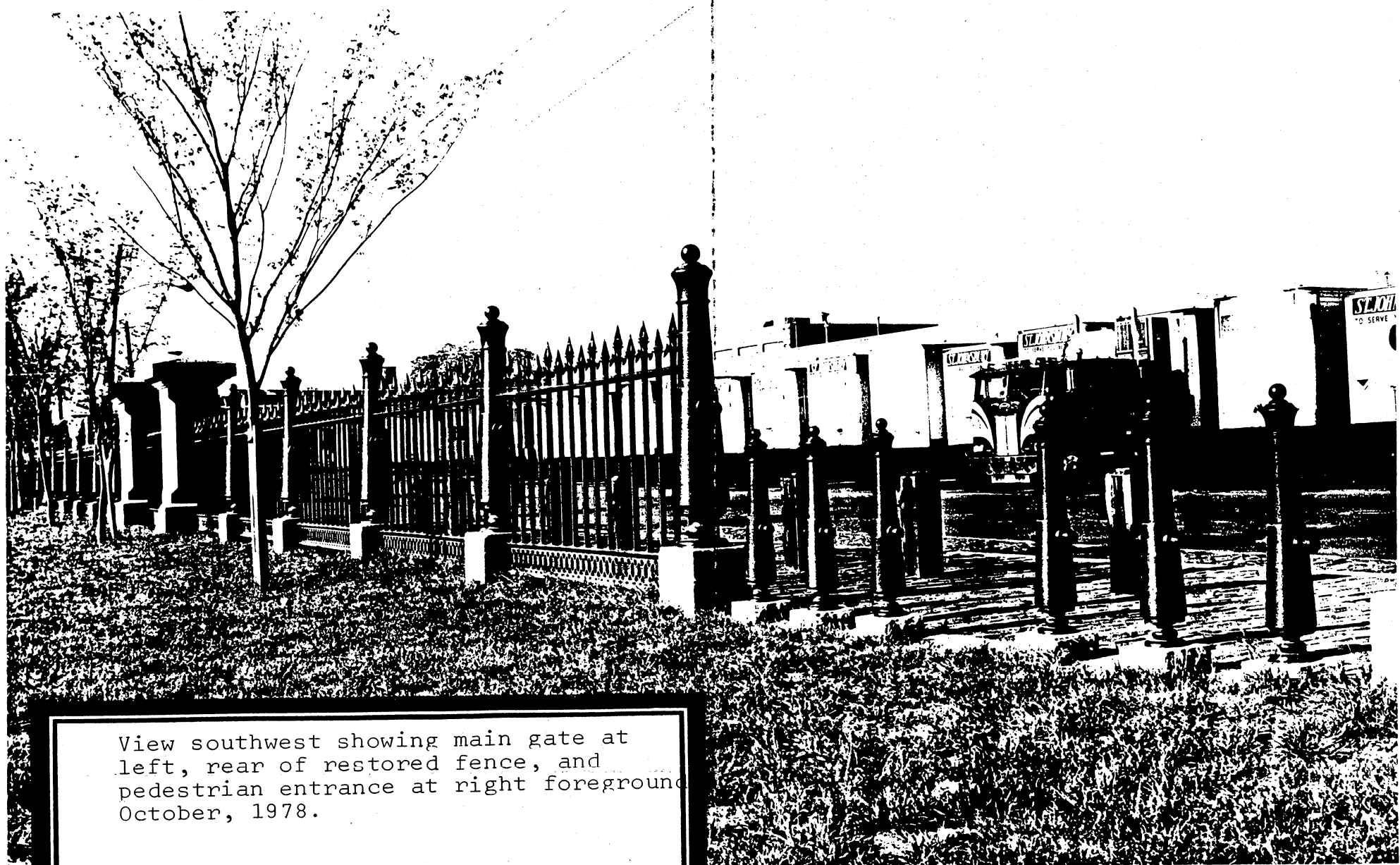

View southwest showing main gate at left, rear of restored fence, and pedestrian entrance at right foreground. October, 1978.

an additional area of 108,400 square feet lying within 100 feet of the park boundary on the north, south and west.

On the east, a corridor 50 feet wide on axis with the center line of the park will extend to Vassar Street. This perimeter zone will incorporate portions of the former St. Johnsbury property along the northwest side of Waverly Street, including 377 feet of the Waverly Street facade of the existing building; portions of three vacant lots owned by M.I.T. west of the Conrail tracks; a section of the Conrail right-of-way; and portions of two lots east of the tracks, also owned by M.I.T. Also included are Talbot and Reardon Streets in their entirety, and portions of Waverly and Anglim Streets, the latter an unaccepted public way occupied by a spur track ~~owned by the Stimpson Realty Company. No existing buildings~~ are included, although AS&E's exterior of the former St. Johnsbury terminal will fall within the district when it is completed. This extension will not fall under historic district review because construction is underway.

These properties and their ownership are summarized in the accompanying table.

Properties Located in the Proposed Fort Washington Historic District

<u>Assessors Plan Parcel Number</u>	<u>Street Address</u>	<u>Owner</u>	<u>Use</u>	<u>Building Date</u>
66-74	95-111 Waverly Street	City of Cambridge	Fort Washington Park	----
66-73	117-139 Waverly Street	M.I.T.	Parking lot	----
66-99	91 Waverly Street	M.I.T.	Parking lot	----
66-138	66-116 Waverly Street taxed at 6-24 Allston Street	American Science & Engineering	Offices	1946 1981
61-9	269 Vassar Street	M.I.T.		----
61-12	277-287 Vassar Street	M.I.T.	Parking lot	----

Source:
Cambridge Assessors Office
September 16, 1981

II. The Nature of Historic District Protection

The objective of the Cambridge Historical Commission in proposing historic district status for Fort Washington is to provide protection against inappropriate development for the only remaining fortification associated with the

Siege of Boston. Historic district status provides this protection by giving the Historical Commission the authority to review all new construction, additions, and alterations to structures within the district and visible from a public way. This authority is derived from Chapter 40C of the General Laws of the Commonwealth, and has been exercised by the Historical Commission in four districts in Cambridge from 1963 to 1976 and in one consolidated district since that time.

Just as zoning is intended to protect property owners against inappropriate uses or bulk of buildings next door or in the immediate neighborhood, so historic district protection is intended to prevent incongruous changes or developments in the district which might hurt or destroy the character and setting of a site with historical significance.

Thus, when a property owner proposes alterations or changes, there is a public hearing before a building permit will be issued. Under the Historic Districts Act, the Historical Commission provides that notice and hearing, and then issues one of three certificates: (1) Certificate of Appropriateness; (2) Certificate of Hardship; or (3) Certificate of Nonapplicability.

A. Objectives

The purpose of historic districting is stated in the enabling legislation, Chapter 40C of the General Laws. The Act is intended "to promote the educational, cultural, economic and general welfare of the public through the preservation and protection of the distinctive characteristics of buildings and places significant in the history of the Commonwealth and its cities and towns or their architecture, and through the maintenance and improvement of settings for such buildings and places and the encouragement of design compatible therewith."

The first Massachusetts historic districts, on Beacon Hill and in Nantucket, were established by special Acts in 1955 following an opinion of the Massachusetts Supreme Judicial Court that such legislation was a constitutional use of the State's power to promote the public welfare. The Massachusetts Court cited a United States Supreme Court decision in the case of Berman vs. Parker (1954):

The concept of the public welfare is broad and inclusive.... The values it represents are spiritual as well as physical, aesthetic as well as monetary. It is within the power of the legislature to determine that the community should be beautiful as well as healthy, spacious as well as clean, well balanced as well as carefully patrolled.¹

More recently, the Massachusetts Supreme Judicial Court has ruled in connection with the right of a municipality to prohibit billboards, that "aesthetics alone may justify

¹348 U.S. 26 (1954)

the exercise of the police power," and quoted Article 97 of the Amendments to the Massachusetts Constitution, which established as state policy the right of the people to "the natural, scenic, historic, and aesthetic qualities of their environment...."²

The courts have also upheld historic districts on the grounds of their contribution to the economic well-being of a community. The Supreme Judicial Court in the Nantucket opinion noted that "the erection of a few wholly incongruous structures might destroy one of the principal assets of the town."³ The courts have noted that these benefits may accrue to the individual property owner as well as to the community at large, but have considered that public purposes are served ~~if the public good outweighs private costs.~~⁴

It has been judicially determined that historic district legislation does not constitute a taking of private property without compensation, and it has been noted that many zoning ordinances are as demanding in their application.⁵ Once again, the public benefit is held superior to a reasonable degree of private sacrifice, a principle that was recently upheld by the United States Supreme Court in confirming the landmark designation of Grand Central Terminal in New York City.

² John Donnelly & Sons vs. Outdoor Advertising Board (1975)

³ 333 Mass. 773, 780 (1955)

⁴ T. J. Reed, Land Use Controls in Historic Areas, 44

Notre Dame Lawyer 3, 387.

⁵ 333 Mass. 773, 778 (1955)

Power to establish historic districts is not given lightly. Chapter 40C requires a thorough survey and report on the areas proposed for protection, review and comment by other public agencies, a public hearing with notification of all affected property owners, and passage of the historic district ordinance by the City Council by a two-thirds majority. Once a district has been established the local historical commission holds the power to review all construction and alterations of structures that will be visible from a public street, sidewalk, or park. This authority cannot be arbitrarily exercised, however; the legislation requires that a commission "shall not make any recommendations or requirement except for the purpose of preventing developments incongruous to the historic aspects or architectural features of the ... district." The Supreme Judicial Court, in reviewing the Nantucket ordinance in 1955, warned that enforcement actions would need to be carefully circumscribed, since in some instances decisions of an historical commission might give rise to "peculiar hardship and remoteness from the legitimate purpose of the act" which would amount to unconstitutional applications of it. Accordingly, the legislation establishes a time limit requiring a commission to act on a petition within a given period, and provides for appeal of commission decisions.

B. Administration of Historic Districts

The administration of historic districts is guided in every respect by the provisions of Chapter 40C, except as especially provided for in the local ordinance creating the district, or as established as a policy by an historical

commission.

All buildings of whatever size or function, as well as all structures, including signs, fences, walks, terraces, driveways, walls, light fixtures, or the like, which are "open to view from a public street, public way, public park or public body of water", fall within the review of the commission. Building projects which must be reviewed include construction, reconstruction, erection, demolition, removal, and changes in color as they affect exterior features of a structure visible from a public street, way, or park. Such features include, but are not limited to, the kind, color, and texture of exterior building materials, the color of paint or materials used on exterior surfaces, and the type and style of windows, doors, lights, signs, and other fixtures.

Although the legislation provides for commission review of every exterior architectural feature visible from a public way, certain items may be excluded from control when the ordinance is drafted. These may include terraces, walkways, driveways, and sidewalks; walls and fences; temporary signs and structures; storm doors and windows, air conditioners, lighting fixtures, antennae and the like; and color of paint and roofs. An historical commission may also impose dimensional and set-back requirements more stringent than required by the zoning code. However, a commission may make no conditions "except for the purpose of preventing developments incongruous to the historic aspects or architectural characteristics ... of the historic district."

The commission issues three types of certificates as the basic administrative method by which proposed alterations are reviewed, and no building or demolition permit for work in a district can be issued until a certificate has been issued.

Each type of certificate is issued after evaluation of the circumstances. A certificate of appropriateness will be issued when the commission has determined that a project is not incongruous with the historic district; this is the most common certificate issued by most commissions. A certificate of nonapplicability is issued for a project which the commission determines does not involve an exterior feature, or one not visible from a public way. Finally, a certificate of hardship may be issued when refusal to issue ~~a certificate of appropriateness or nonapplicability would~~ cause the applicant substantial hardship, financial or otherwise, as long as there is no substantial detriment to the district.

Application for a certificate is made by submitting a description of the proposed alteration along with plans or photographs sufficient for the commission to judge the effect of the proposed alteration. The commission must determine within fourteen days of an application whether a certificate is required.

In passing on applications for certificates, a commission is required to consider, among other things, the historic and architectural values and significance of the site, building, or structure, the general design, arrangement, texture, material and color of the features involved, and the relationship

of these features to similar features of buildings in the surrounding area. In the case of new construction or additions to existing buildings, the commission must consider the size and shape of the building, in relation to both its site and surrounding buildings, and can establish a policy to exclude features from control after the historic district is established. The commission can also establish appropriate designs or lists of paint colors, roofing materials, or the like for the guidance of property owners.

A commission cannot review alterations to interiors of structures, nor alterations which are not visible from a public way, even though such alterations may still be within a district. Furthermore, landscaping with plants, trees or ~~shrubs is specifically excluded from review, and the commission~~ is not concerned with ordinary maintenance, repair, or replacements that do not involve a change in exterior appearance. Enactment of an historic district in no way requires owners to alter their properties, nor requires restoration of a structure to any set historical period. Work must be reviewed only if it involves a change from that which exists on enactment of the ordinance; maintenance or replacement of an architectural feature incongruous with the historic or architectural qualities of the district may take place without a certificate as long as there is no change in exterior appearance.

If the commission deems the alteration to require a certificate, it may take action either through a public hearing or by simple vote after notice to surrounding property owners.

A public hearing is held in the event that the alterations are deemed substantial; surrounding property owners are given two weeks' notice, and the application is given consideration in terms of the criteria listed above. However, if the application involves an alteration which is considered insubstantial in its effect, the commission may simply vote on the matter after allowing ten days for comment by surrounding property owners.

If a commission disapproves the application for a certificate, it must give its reasons to the applicant in writing. However, a commission is specifically authorized to make recommendations for changes which would make the application acceptable. If the applicant modifies the ~~application to conform to the commission's suggestions,~~ a certificate must be issued.

An applicant aggrieved by a decision of a commission may appeal to the Superior Court sitting in equity for that county; costs are not assessed against the person appealing unless the court finds that action was taken in bad faith. Similarly, the Superior Court may enforce the provisions of the historic district legislation through injunction, court order, and fine.

C. Establishment of an Historic District

Procedures for the organization of an historic district are established by the Massachusetts Historical Commission under the provisions of Chapter 40C. An existing historical commission is empowered under the legislation to initiate consideration of possible historic districts, and must

conduct a survey as the basis for its decisions. In the course of preparing the required preliminary report, the commission must consider the options set forth in the legislation for exemption of certain architectural features from review, outline the exact boundaries of the area to be included in the historic district, present a full architectural and historical justification for the area, and draft an ordinance implementing the district.

The preliminary report must be submitted to the local planning board and the Massachusetts Historical Commission, and distributed to affected property owners as well. A public hearing, for which all affected property owners must be given two weeks written notice, must be held no less than ~~sixty days after the report has been released.~~ The object of the public hearing is to allow comments to be officially recorded.

After the public hearing, the historical commission prepares a final report which takes into account the comments received at the public hearing and the recommendations of the planning board and the Massachusetts Historical Commission. The report is then submitted to the City Council, where a two-thirds majority vote is required for the ordinance to be adopted. The district finally goes into effect when an official map showing the boundaries of the district is filed with the registry of deeds.

III. Administration of Existing and Proposed Historic Districts

The Cambridge Historical Commission was established in 1963 to administer four historic districts around Cambridge Common and along Brattle Street, to conduct a survey of Cambridge architecture, and to engage in other duties concerned with the protection and improvement of architecturally and historically important buildings and sites.

The four original historic districts were established to protect a number of individually important sites and open spaces. The Cambridge Common District was intended to protect the Common and its surroundings, and did so by establishing a perimeter boundary line running 100 feet from and parallel to ~~the curbing around the Common.~~ Two other major features, the complex of buildings making up the oldest structures in Harvard Yard and the Old Burying Ground, were also included, as were a number of modern structures which fell within the perimeter. The objective of the Fort Washington Historic District is similar: to protect an historic public open space from inappropriate development of its surroundings. The other districts in Old Cambridge were established mainly to protect a number of residential properties associated with the Tory estates and the Revolution, although many significant later structures were included as well. The combined and expanded Old Cambridge Historic District approved in 1976 had additional objectives, among them the protection of Mason and Brattle Streets and Elmwood Avenue as Tory Row and the historic Path

to Watertown. This added area also included many buildings of historic and architectural significance.

A. Design Objectives

Many historical commissions have attempted to establish a single architectural style as the only acceptable one for new construction or alterations in historic districts, and this has been a legitimate cause of concern among property owners and architects. The Cambridge Historical Commission has recognized that no single style is "correct", and that a large measure of the architectural and historical value of the Old Cambridge Historic District stems from the diversity of periods and architectural styles represented there. In the case of 133 Brattle Street, the Commission explicitly ~~accepted an uncompromising modern design.~~ Historic district review is necessary in such areas to protect against developments which are incompatible in scale, siting, or design, not to guard against construction in any particular style of architecture.

The 100 foot perimeter and corridor to Vassar Street proposed for the Fort Washington Historic District are designed to protect against inappropriate future development, not to regulate alterations to or demolition of existing buildings. The effect of limiting protection to this perimeter will be to control the height and facade treatment of new buildings only as they face the park. The facades which are located outside the district will not be subject to review.

The order establishing the Fort Washington Historic District has been drafted to conform with the provisions of Chapter 40C of the Massachusetts General Laws, and will cover the exterior appearance of future buildings in the district as well as any future alterations to the park itself. Designs of sidewalks and street furniture in the district will be specifically included.

APPENDIX

- A. Proposed Amendment to the Cambridge Historical Commission
Ordinance

Proposed Amendment to the Cambridge Historical Commission Ordinance

Be it ordained by the City Council of Cambridge as follows:
Chapter Two entitled "Administration" is hereby amended by
adding at the end of Section 2-146 the following paragraph:

2. There is further established under the provisions of the
Historic Districts Act (M.G.L. Ch. 40C) a Fort Washington
Historic District consisting of Fort Washington Park and
an additional area as shown on the map entitled "Fort
Washington Historic District, 1981" attached to and made
a part of this ordinance.

September 11, 1981
Cambridge Historical Commission

Final Planning Board Recommendation. Includes a Complete Package of Text and Map Changes to the Cambridge Zoning Ordinance.

Cambridge, March 26, 1981

To the Honorable, the City Council of the
City of Cambridge:

Revised May 19, 1981
Final Planning Board
Revision June 16, 1981

The undersigned respectfully pray
that the Zoning Ordinance of the City of Cambridge be amended as
follows:

A. AMEND THE TEXT OF THE ORDINANCE AS FOLLOWS:

1. In Article 11.000, Special Regulations, add the following new section:

"11.80 FORT WASHINGTON OVERLAY DISTRICT

- 11.81 Establishment and Scope. There is hereby established a Fort Washington Overlay District which shall be governed by the Regulations specified in this Section 11.80. It is the intent of this section that these regulations will apply to a single area described generally as Fort Washington and portions of certain abutting lots.
- 11.82 Purpose. It is the purpose of this Section 11.80 to augment existing zoning regulations in order to encourage development which will (1) recognize the historic significance of Fort Washington, (2) protect and enhance the use and enjoyment of Fort Washington, (3) articulate Fort Washington as a well defined urban park and (4) promote residential uses and limit off-street parking adjacent to Fort Washington.
- 11.83 Applicability. The Fort Washington Overlay District shall be an overlay district on the zoning map established in Section 3.20.
- 11.831 The buildings and land uses within said district shall be controlled by the pertinent regulations within the base zoning districts, except as modified by the requirements of this Section 11.80 which shall apply in addition to regulations imposed by the base zoning map designations. Where the base zoning regulations differ from the requirements of this Section 11.80, the stricter provisions shall apply.
- 11.832 Buildings and land uses which are controlled by the regulations of Section 13.70 (PUD-6) shall also meet the development regulations of this Section 11.80. However, special permits required in this Section 11.80 may be allowed by the Planning Board within the scope of the special permit review for Section 13.70 and shall not require a separate review process.

11.84 Land use standards in the Fort Washington Overlay District.

11.841 No building, structure or land in the Fort Washington Overlay District may be used, erected or designed to be used, in whole or in part, for any use without a special permit from the Planning Board.

11.842 The Planning Board shall determine that the proposed use will meet the purposes of this Section 11.80 and that the criteria specified in Section 10.43 will be satisfied.

11.85 Dimensional standards in the Fort Washington Overlay District.

11.851 Maximum Building Height. The transition from Fort Washington, a public open space, to private development should not be abrupt. Therefore, the maximum height of buildings in the Fort Washington Overlay District shall be 35 feet. However, the maximum height of a townhouse development shall comply with the requirements of subsection 11.153.

2. In Article 13.000, Planned Development Districts, add the following new section establishing regulations for a PUD overlay district in the Cambridgeport Revitalization District:

13.70 PUD-6 DISTRICT: DEVELOPMENT CONTROLS

13.71 Purpose. The PUD-6 district is intended to provide for the creation of a high quality mixed use urban environment which permits development of general and technical (research and development) offices with supporting commercial activities, light industrial uses, and residential uses at a larger scale than the Industry B-2 base zone. The PUD-6 district is also intended to provide a process which encourages investments and guides the nature of specific proposals to maximize public benefit. Specific objectives of the PUD-6 district include, but are not limited to, the following:

- To provide adequate light and air.
- To secure safety.
- To encourage housing for persons of all income levels, located so as to reinforce existing residential patterns wherever possible.
- To facilitate the adequate provision of transportation, including the construction of new roadway linkages.
- To lesson the traffic congestion in the streets.

- To develop coordinated and useable open space which is publicly accessible.
- To encourage development which will contribute to an upgrading of economic activity and add diversity to job opportunities.
- To encourage coordinated developments which: maximize efficiency of energy consumption, eliminate conflicts between non-compatible land uses and which create buffers between existing residential areas and new non-residential areas.

13.72 Uses allowed in a PUD-6 District. The uses listed in this Section 13.72, alone or in combination with each other, shall be allowed upon permission of the Planning Board.

13.721 Residential Uses.

- (1) Townhouse development. Any special permits for parking arrangements for townhouse development required by Section 11.10 shall be granted by the Planning Board in a planned unit development in a PUD-6 District.
- (2) Multi-family dwellings
- (3) Hotels and motels

13.722 Transportation, Communication, Utility Uses and Institutional Uses. All uses listed in Sections 4.32 and 4.33 and which are allowed or conditionally allowed in the base zoning district.

13.723 Office and Laboratory Uses. All uses listed in Section 4.34.

13.724 Retail Business and Consumer Service Establishments.

- (1) Stationery and office supply store
- (2) Printing and reproduction service establishment, photography studio
- (3) Other store for retail sale of merchandise located in a structure primarily containing non-retail uses, provided that no such establishment shall exceed 15% gross floor area of the structure and that no manufacturing, assembly or packaging occur on the premises.

- (4) Barber shop, beauty shop, laundry and dry cleaning pick-up agency, shoe repair, self-service laundry or other similar establishments.
- (5) Restaurants or other eating and drinking establishments listed in subsection 4.35 e, f, and g.
- (6) Theater or hall for public gatherings.
- (7) Bowling alley, skating rink, tennis center or other commercial recreation establishments.

13.725 Light Industrial Uses.

- (1) Manufacturing, processing, assembly and packaging of products listed in Section 4.37(a), (b) 1-15 and 4.37(f).

13.726 Other Uses. Any use not listed in subsections 13.721-13.725 shall be allowed only upon written determination by the Planning Board that such use is consistent with the objectives of the PUD-6 district and is necessary to support the predominant uses in the district.

13.73 Uses Required in the PUD-6 District. The uses listed in this Section 13.73 alone or in combination with each other, or other uses permitted in the PUD, shall be required within any planned unit development having an FAR greater than 1.5.

- (1) Residential Uses:

Townhouse development
Multi-family dwellings

- (2) Light Industrial Uses:

Manufacturing, processing, assembly and packaging of products listed in subsections 4.37(a), (b) 1-15 and 4.37(f).

At least 50% of the proposed gross floor area in excess of 1.5 FAR shall be devoted to any of the above uses alone or in combination with each other.

13.74 District Dimensional Regulations. Where the base zoning regulations differ from this requirement, the less restrictive provision shall apply to part or all of the development parcel in that location.

- (1) Massachusetts Avenue to Pacific Street

The maximum ratio of floor area to the total area of the development parcel shall be 2.5.

(2) Pacific Street to Memorial Drive

The maximum ratio of floor area to the total area of the development parcel shall be 2.0.

In no instance shall the floor area ratio of any contiguous portion of a Development Parcel exceed an FAR of 4.0.

- 13.742 The minimum size of the development parcel for PUD shall be one (1) acre. The Planning Board may allow development parcels containing less than one acre but at least 25,000 square feet if the predominant use of the development is devoted to multi-family or townhouse use. There shall be no specified minimum lot size for lots located within a development parcel. The Planning Board shall approve all lot sizes located within a development parcel. A development parcel within the PUD-6 district may contain non-contiguous lots. However, in no instance shall non-contiguous lots be separated by more than 1200 feet measured in a straight line from lot to lot.
- 13.743 For the purpose of computing residential density, the minimum land area for each dwelling unit shall be 600 square feet. Residential density shall be computed based on the entire development parcel.
- 13.744 There shall be no minimum width for the development parcel and no minimum width for lots located within the development parcel. There shall be no other minimum required front, rear and side yard requirements for a development parcel or for lots located within a development parcel. The Planning Board shall approve all such building setbacks.
- 13.745 A development parcel which is located in the Fort Washington Overlay District shall meet the development regulations of that Section 11.80. The Board may waive this requirement only upon written determination that such variation does not contradict the planning objectives of the PUD-6 district and the Fort Washington Overlay District.
- 13.75 Height
- 13.751 The maximum height of any building shall be 120 feet, except as modified in Section 13.791.
- 13.76 Open Space Requirements
- 13.761 Definition of Open Space. For the purpose of this subsection 13.76 open space shall mean a part or parts of a development parcel, lot or building reserved for the

purpose of providing light and air, or scenic, recreational or similar purposes. Such open space shall, in general be available for entry and use by the occupants of the building with which it is associated and the general public. Open space shall include parks, plazas, lawns, landscaped areas, water bodies, decorative plantings, pedestrian ways as listed in subsection 14.452 and active and passive recreation areas, including playgrounds and swimming pools.

13.762 Minimum Open Space Requirements

- (1) The minimum amount of open space to be provided on each development parcel shall be equal to 15 percent of the land area.
- (2) Required open space on the ground level shall have a minimum dimension of 20 feet; such required open space shall not have a slope greater than 10%.
- (3) Open space at other levels must be open to the sky and, except for balconies, generally accessible to the public. These areas shall have a minimum dimension of ten (10) feet and a minimum area of 200 square feet.
- (4) At least 50 percent of the open space required in this subsection 13.762 shall be provided at finished grade level.

13.77 Special Requirements for Townhouse and Multi-Family Dwellings PUD-6.

13.771 Any townhouse or multi-family development containing ten or more dwelling units shall make provision for units suitable for and available to low- and moderate-income households in an amount equal to at least ten (10) percent of the total number of units authorized.

13.772 To fulfill the requirements of this subsection 13.77 any one or combination of the following mechanisms may be employed:

- (1) Participation in any federal, state or city program which will guarantee the provision of housing units for low- and moderate-income households.
- (2) Cash payment to the City of Cambridge administered by the Community Development Department to be used to make available housing units for low- and moderate income households in a manner and at locations approved by or in conformance with guidelines adopted by the Cambridge City Council.

The amount of such payment shall be satisfactory to the Board but in no case shall it exceed the equivalent in value of the units which would otherwise have been provided within the development.

- (3) Any other mechanism satisfactory to the Board. Provision of the required low- and moderate-income units may be satisfied by the applicant with the construction or purchase of alternate units outside the development parcel, the location of which shall be satisfactory to the Board. In general such units shall be constructed or purchased in city neighborhoods determined by the Board to have insufficient numbers of low- and moderate-income housing units.

- 13.773 The required low- and moderate-income units shall be intended and designed for families and shall contain a minimum of two bedrooms. Dwelling units intended principally to serve the elderly shall not fulfill the requirements of this sub-section 13.77. It is preferred that the units be located in townhouse or mid-rise residential structures.
- 13.774 The units shall be dispersed throughout the development and not concentrated in any one location.
- 13.775 For the purpose of this section, low- and moderate-income households shall be as defined by guidelines established from time to time by the Federal Department of Housing and Urban Development or any successor agency.

All households occupying the low- and moderate-income units shall be certified as eligible by the Cambridge Housing Authority or other agent of the City of Cambridge approved by the City Council.

- 13.776 In granting approval to construct housing under this sub-section 13.77 the Board shall be satisfied that the units to be provided to low- and moderate-income households, or equivalent units, shall be available for a period of at least fifteen (15) years.
- 13.777 Where the housing is to be constructed in stages the required low- and moderate-income units shall be provided in each stage in the same proportion as required for the total development.

13.78 Parking and Loading Requirements

Development in the PUD-6 district shall conform to the off-street parking and loading requirements set forth in Article 6.000, except as modified by Section 13.78.

13.781 Off-street parking facilities shall be provided as follows:

- (1) Townhouse and Multi-family: 1 space per dwelling unit.
- (2) Transient Accommodations:
Hotel: 1 space per 2 sleeping rooms
Motel: 1 space per motel unit

Additional parking spaces shall be provided for public restaurants: (1) in excess of 2000 square feet when located in a hotel or motel containing up to 100 rooms, (2) in excess of 5000 square feet in a hotel or motel containing between 101 and 250 rooms, and (3) in excess of 8000 square feet in a hotel or motel containing more than 250 rooms. The number of such spaces shall be 1 space per 30 seats. Additional parking spaces shall also be provided for function rooms in an amount equal to 1 space per 300 square feet of floor area contained in such rooms.

- (3) Institutional, retail and office: 1 space per 1000 square feet of gross floor area
- (4) Public Assembly: 1 space per 15 seats
- (5) Restaurants or other eating and drinking establishments: 1 space per 15 seats

13.79 Development Review. The Planning Board in reviewing development proposals in the PUD-6 district shall find that the proposed development provides substantial public benefits which contribute to achieving the purpose and objectives of the PUD-6 district as stated in Section 13.71 and that the development proposed adequately addresses all of the criteria detailed below.

13.791 Development Criteria

- (1) Location, Use and Density Guidelines.

Any Planned Unit Development proposal in PUD-6 shall, in its mix of uses, density and location, be consistent with the following:

- (a) Between Massachusetts Avenue and Pacific Street the highest densities, greatest height of buildings, and uses generating the largest volumes of traffic shall be located toward Massachusetts Avenue and the railroad right-of-way to the east. The lowest densities and heights, and residential uses shall be encouraged along the Brookline Street corridor.

- (b) In the area between Pacific Street and Erie Street the retention and expansion of light industry uses shall be encouraged; all development is encouraged to be of low density and moderate height.
 - (c) Between Erie Street and Memorial Drive the highest densities, greatest height of buildings, and uses generating the largest volumes of traffic shall be located toward Memorial Drive. New roadways to improve circulation in the area shall be provided within the scope of and concurrent with any PUD development between Henry Street and Memorial Drive; such improvements shall be reasonably related to the development proposed as well as to other related developments in the Cambridgeport area. Residential uses should be located so as to reinforce existing residential neighborhoods.
- (2) Site Planning. The site plan shall provide for safe, efficient, convenient, and harmonious grouping of structures, uses, and facilities; for appropriate relation of space inside and outside buildings to intended uses and structural features, and for preservation of desirable natural or historic features.
 - (3) Perimeter and Transition. Any part of the perimeter of a PUD which fronts on an existing street, public open space, residential zoning district line, or any other zoning district which limits the intensity of development to a level well below that permitted in the PUD, shall be so designed as to complement and harmonize with adjacent land uses with respect to use, scale, density, setback, bulk, height, landscaping and screening.
 - (4) Scale. In evaluating a Development Proposal providing building height in excess of 85 feet or 35 feet where such height limit is imposed by the base district, the Planning Board shall give consideration to evidence presented on the following:
 - (a) that increased height will not cast shadows or alter air currents in ways that will unreasonably limit the amount of light and air reaching other buildings in the vicinity to a significantly greater extent than if the building height did not exceed the base district height;
 - (b) that increased height would mitigate detrimental environmental impacts such as excessive ground coverage, diminution of open space and monotonous development;
 - (c) that increased height would not adversely affect and would result in increased sensitivity to the visual and physical characteristics of the particular location;

- (d) that increased height would result from actions taken to lessen the impact of traffic and parking on the surrounding area;
 - (e) that the orientation and location of the proposed structure would not otherwise diminish the health and safety of the area around the development;
 - (f) that the orientation and location of the proposed structure is designed so as to achieve maximum energy efficiency.
- (5) Traffic and Circulation. In its mix of uses, intensity of development, location, and proposed transportation improvements, the PUD shall be designed to minimize any negative impact on the adjacent residential neighborhood due to increased volumes of traffic, changed patterns of traffic movement, or an altered mix of vehicular types in the traffic stream.

Wherever possible the PUD shall enhance the movement of traffic within the industrial district and direct traffic related to its operation to Massachusetts Avenue or Memorial Drive through the industrial district.

The Board may require, as a condition of Special Permit approval, the provision of certain transportation improvements or other mitigating measures necessary to reduce the impact of the proposed PUD development on inadequate streets within the district as a whole or in the residential neighborhood.

Such improvements or measures may include, but not be limited to, reduction in the total floor area proposed, alteration in the mix of uses, incorporation of streets within the development to serve general public traffic needs, and improvements to adjacent or impacted public streets and intersections.

Such improvements or measures shall be reasonably related to increased traffic contribution made by the proposed development.

- (6) Pedestrian Circulation. Walkways shall form a logical, safe and convenient system for pedestrian access to all dwelling units, project facilities and principal off-site pedestrian destinations.
- (7) Open Space. To the maximum extent possible the required open space shall:

- (a) be organized in units of sufficient size to have a significant visual impact on the district;
 - (b) provide opportunities for active and passive recreation for persons working or living within the district or the adjacent residential neighborhood;
 - (c) be located so as to provide a green buffer and transition between residential uses and districts and more intensive office and industrial uses; and
 - (d) be designed and located so as to encourage the widest possible use and enjoyment by the general public.
- (8) Housing and Job Opportunities. A PUD shall contribute to the residential and/or industrial employment base in the Cambridgeport area. Both uses shall be appropriately located so as to complement existing uses and to minimize conflicts between noncompatible uses.

The PUD development shall not unreasonably reduce the inventory of existing industrial activity in the district and shall, where possible, contribute additionally to the diversity of industrial employment in Cambridgeport.

3. Amend subsection 11.72 of Section 11.70, Employment Plan Compliance Procedure, so that it reads as follows:

"11.72 Applicability. The provisions of this Section 11.70 shall apply to new economic development activity in the Alewife Revitalization District and the Cambridgeport Revitalization District and in other major economic revitalization areas designated by City Council through amendments to this subsection 11.72. The Alewife Revitalization District shall be that area contained within the comprehensive Alewife Area Rezoning Amendment ordained on June 16, 1980. The Cambridgeport Revitalization District shall be that area contained within the comprehensive Cambridgeport area rezoning amendment ordained at the time of adoption of this zoning amendment. For purposes of this Section 11.70, the following shall be considered new economic development activity."

4. Amend Footnote (c) in subsection 5.34 to read as follows:

"(c) 35 foot height limit within 100 feet of a residential district."

5. Amend Article 4.000, Section 4.40 Footnotes 33 and 34 by deleting the following:

33. "Provided that no such article exceeds two hundred pounds in weight"

34. "(a) in Industry A, A-1, A-2 and B-2 districts any fully assembled product regularly produced shall not exceed two hundred pounds in weight,"

6. Create a new Business B-3 District by amending the Zoning Ordinance as follows:

- I. Amend Section 3.10, Division of the City into Zoning Districts by inserting a new number 19 as follows:

19. Business B-3 District

Renumber existing numbers 19-27 as 20-28.

- II. Amend Section 4.30, Table of Use Regulations, by adding B-3 after Bus. B, B-1, B-2 to the heading of column eight.

- III. Add a new line to subsection 5.33 Business Districts between line Bus. B-2 and line Bus. C as follows:

Bus B-3 3.0 none 300 none none none none 120^(h) none

(h) For residential uses in the Business B-3 district the maximum height shall be 180 feet.

- IV. Delete footnote 5, subsection 5.33 and substitute therefor the following:

5. A dwelling in a Business B or Business B-3 District shall be subject to the same dimensional requirements and other restrictions as a dwelling in a Residence C-3 District.

- V. Delete footnote 10, subsection 4.40 and substitute therefor the following:

10. Except in a Business B or Business B-3 District the use shall be subject to the limitations specified in Section 4.26.

- VI. Amend subsection 6.36, Schedule of Parking and Loading Requirements by adding B-3 after Bus. B-1, B-2 to the heading of column four.

- B. AMEND THE ZONING MAP BY CHANGING THE DISTRICT DESIGNATIONS FOR THE FOLLOWING AREAS:

1.0 Rezone to Business B-3 (with a Planned Unit Development District-6) that area presently zoned Business B and Industry B which is circumscribed by a line beginning at a point, said point being the intersection of the centerline of Massachusetts

Avenue and the northeasterly projection of a line 100 feet southeast of and parallel to the southeasterly sideline of Brookline Street;

- 1.1 Thence proceeding in a southeasterly direction along the centerline of Massachusetts Avenue for approximately 2230 feet to its intersection with the centerline of Vassar Street;
- 1.2 Thence turning and proceeding in a southwesterly direction along the centerline of Vassar Street and its projection for approximately 150 feet to its intersection with a line 100 feet southwest of and parallel to the southwesterly sideline of Massachusetts Avenue, as shown on Assessor's Plat #56;
- 1.3 Thence turning and proceeding in a northwesterly direction along a line 100 feet southwest of and parallel to the southwesterly sideline of Massachusetts Avenue for approximately 395 feet to its intersection with the centerline of Albany Street;
- 1.4 Thence turning and proceeding in a westerly direction along the centerline of Albany Street for approximately 265 feet to its intersection with the southeasterly projection of the centerline of Cross Street;
- 1.5 Thence turning and proceeding in a northwesterly direction along the centerline of Cross Street and its projection and extension for approximately 530 feet to its intersection with the centerline of Lansdowne Street;
- 1.6 Thence turning and proceeding in an easterly direction along the centerline of Lansdowne Street for approximately 120 feet to its intersection with the southeasterly projection of the centerline of Green Street;
- 1.7 Thence turning and proceeding in a northwesterly direction along the centerline of Green Street and its projection for approximately 1090 feet to its intersection with a line 100 feet southeast of and parallel to the southeasterly sideline of Brookline Street;
- 1.8 Thence turning and proceeding in a northeasterly direction along a line 100 feet southeast of and parallel to the southeast sideline of Brookline Street for approximately 150 feet to its intersection with the centerline of Massachusetts Avenue, the point of origin.
- 1.00 Said area includes all or parts of the following parcels of land:
 - 1.01 Premises shown on Assessor's Plat #92:

Even numbers 372 through 458 Massachusetts Avenue, odd numbers 81 through 131 Green Street, numbers 7 through 13 Sidney Street and which includes all or parts of lots numbered 69, 51, 89, 66, 117, 57, 62, 95, 96, 103, 58.

1.02 Premises shown on Assessor's Plat #69:

Even numbers 266 through 358 Massachusetts Avenue, odd numbers 11 through 43 Green Street, number 15 Lansdowne Street, numbers 4 through 22 Blanche Street and which includes all or parts of lots numbered 160, 159, 72, 99, 100, 101, 102, 103, 149, 163, 148, 109, 110, 111, 161, 106, 113, 114, 115, 116, 117.

1.03 Premises shown on Assessor's Plat #68:

Even numbers 180 through 256 Massachusetts Avenue, odd numbers 1 through 47 Cross Street, even numbers 2 through 22 Lansdowne Street and 115 Albany Street, which includes all or parts of lots numbered 47, 50, 51, 19.

1.04 Premises shown on Assessor's Plat #56:

Even numbers 134 through 168 Massachusetts Avenue, 93 Vassar Street and 114 Albany Street, which includes all or parts of lots numbered 5, 7, 9 and 4.

- 2.0 Rezone to Business A-1 that area presently zoned Business A and which is circumscribed by a line beginning at a point, said point being the intersection of the centerlines of Brookline Street and Franklin Street;
- 2.1 Thence proceeding in a southerly direction along the centerline of Brookline Street for approximately 730 feet to its intersection with the northwesterly projection of the centerline of Pacific Street, as shown on Assessor's Plat 92;
- 2.2 Thence turning and proceeding in a southeasterly direction along the centerline of Pacific Street and its projection for approximately 120 feet to its intersection with a line 100 feet southeast of and parallel to the southeasterly sideline of Brookline Street;
- 2.3 Thence turning and proceeding in a northeasterly direction along a line 100 feet southeast of and parallel to the southeastern sideline of Brookline Street for approximately 730 feet to its intersection with the centerline of Franklin Street, as shown on Assessor's Plat #92;
- 2.4 Thence turning and proceeding in a northwesterly direction along the centerline of Pacific Street and its extension for approximately 120 feet to its intersection with the centerline of Brookline Street, the point of origin.
- 2.00 Said area includes all or parts of the following parcels of land. (total area is approximately 1.7 acres)
- 2.01 Premises shown on Assessor's Plat #92:
Even numbers 46 through 104 Brookline Street, 119 Pacific Street, 41-47 Pilgrim Street, 154 Franklin Street, which includes all or parts of lots numbered 112, 115, 22, 105, 106, 19, 114, 82, 91, 4, 3, 116.

- 3.0 Rezone to Industry B-2 (with a Planned Unit Development Overlay District-6) that area presently zoned Industry B which is circumscribed by a line beginning at a point, said point being the intersection of a line 100 feet southeast of and parallel to the southeasterly sideline of Brookline Street and the centerline of Green Street;
- 3.1 Thence proceeding in an easterly direction along the centerline of Green Street for approximately 1090 feet to its intersection with the centerline of Lansdowne Street as shown on Assessor's Plat #92 and 68;
- 3.2 Thence turning and proceeding in a westerly direction along the centerline of Lansdowne Street for approximately 120 feet to its intersection with the northwesterly projection of the centerline of Cross Street;
- 3.3 Thence turning and proceeding in a northeasterly direction along the centerline of Cross Street and its projection and extension for approximately 530 feet to its intersection with the centerline of Albany Street;
- 3.4 Thence turning and proceeding in a easterly direction along the centerline of Albany Street for approximately 265 feet to its intersection with a line 100 feet southwest of and parallel to the southwesterly sideline of Massachusetts Avenue;
- 3.5 Thence turning and proceeding in a northeasterly direction along a line 100 feet southwest of and parallel to the southwest sideline of Massachusetts Avenue for approximately 190 feet to its intersection with the northwesterly sideline of the Boston Albany Branch Railroad right-of-way as shown on Assessor's Plat #56;
- 3.6 Thence turning and proceeding in a westerly direction along the northwesterly sideline of the Boston Albany Branch Railroad right-of-way for approximately 1140 feet to its intersection with the southwesterly sideline of lot #7 on Assessor's Plat #55;
- 3.7 Thence turning and proceeding in a northwesterly direction along the southwesterly sideline of lot #7 and its extension on Assessor's Plat #55 for approximately 270 feet to its intersection with the centerline of Pacific Street;
- 3.8 Thence continuing in a northwesterly direction along the centerline of Pacific Street for approximately 1175 feet to its intersection with a line 100 feet southeast of and parallel to the southeastern sideline of Brookline Street;
- 3.9 Thence turning and proceeding in a northeasterly direction along a line 100 feet southeast of and parallel to the southeastern sideline of Brookline Street for approximately 1745 feet to its intersection with the centerline of Green Street, the point of origin.

3.00 Said area includes all or parts of the following parcels of land:
(total area is approximately 45 acres)

3.01 Premises shown on Assessor's Plat #92:

Odd numbers 78 through 144 Green Street, 109 through 155 Franklin Street, 115 Pacific Street, 17 through 63 Sidney Street, which include all or parts of the following lots numbered 33, 34, 31, 35, 36, 90, 84, 85, 40, 41, 42, 43, 44, 115, 19, 112, 114, 4, 3, 116.

3.02 Premises shown on Assessor's Plat #69:

Even numbers 20 through 96 Sidney Street, odd numbers 23 through 85 Pacific Street, numbers 49 through 95 Franklin Street, numbers 10 through 56 Green Street, numbers 4 through 81 Blanche Street and numbers 12 through 30 Auburn Street which include all or parts of lots numbered 62, 147, 146, 61, 60, 58, 77, 78, 124, 125, 80, 129, 130, 131, 133, 132, 164, 53, 54, 51, 50. 49, 156, 155, 158, 157, 150, 153, 57, 138.

- 4.0 Rezone to Industry B-2 with a Planned Unit Development Overlay (PUD-6) that area presently zoned Industry B which is circumscribed by a line beginning at a point, said point being the intersection of the centerline of Pacific Street and the northeasterly projection of a line 100 feet southeast of and parallel to the southeasterly sideline of Brookline Street as shown on Assessor's Plat #95 and proceeding in a southeasterly direction along the centerline of Pacific Street for approximately 395 feet to its intersection of Sidney Street;
- 4.1 Thence continuing in a southeasterly direction along the centerline of Pacific Street and its projection for approximately 1040 feet to its intersection with the northerly sideline of the Boston and Albany Branch Railroad right-of-way as shown on Assessor's Plat #55, and #67;
- 4.2 Thence turning and proceeding in a southwesterly direction along the northwesterly sideline of the Boston and Albany Branch Railroad right-of-way for approximately 1190 feet to its intersection with the westerly sideline of lot #12, as shown on Assessor's Plats #55 and #54;
- 4.3 Thence turning and proceeding in a northwesterly direction along the westerly sideline of lot #12 and its projection, on Assessor's Plat #54 for approximately 275 feet to its intersection with the centerline of Anglim Street, as shown on Assessor's Plat #66;
- 4.4 Thence turning and proceeding in a northerly direction along the centerline of Anglim Street for approximately 100 feet to its intersection with the centerline of Erie Street, as shown on Assessor's Plat #66;
- 4.5 Thence turning and proceeding in a northwesterly direction along the centerline of Erie Street for approximately 770 feet to its intersection with the southwesterly projection of a line 100 feet southeast of and parallel to the southeast sideline of Brookline Street, as shown on Assessor's Plat #95;
- 4.6 Thence turning and proceeding in a northeasterly direction along a line 100 feet southeast of and parallel to the southeastern sideline of Brookline Street for approximately 970 feet to its intersection with the centerline of Pacific Street, the point of origin.
- 4.00 Said area includes all or parts of the following parcels of land: (total area is approximately 30 acres)
- 4.01 Premises shown on Assessor's Plat #95:
Even numbers 82 through 112 Pacific Street, numbers 2 through 34 Tudor Street, numbers 7 and 12 Emily Street, odd numbers 97 through 175 Sidney Street, odd numbers 71 through 103 Erie Street which includes all parts of lots numbered 59, 58, 48, 57, 49, 60, 53, 61, 66, 73, 72, 71, 70, 5, 75, and 44.

4.02 Premises shown on Assessor's Plat #96:

Even numbers 80 through 100 Erie Street, numbers 51 through 90 Hamilton Street, odd numbers 179 through 201 Sidney Street and which includes all or parts of lots numbered 127,126,118, 117,124,109,110,102, and 98.

4.03 Premises shown on Assessor's Plat #54:

Even numbers 240 through 294 Albany Street, number 645 Erie Street and which includes all or parts of lots numbered 7, 16, 19,18,10 and 12.

4.04 Premises shown on Assessor's Plat #67:

Even numbers 2 through 68 Pacific Street, even numbers 98 through 176 Sidney Street, numbers 1 through 64 Waverly Street, odd numbers 221 through 295 Albany Street, odd numbers 9 through 69 Erie Street and which includes all or parts of lots numbered 44,29,47,48,45,46,58,49,52,54,55,33,32,30,12,64,63,62,24,14,61, and 56.

4.05 Premises shown on Assessor's Plat #55:

Even numbers 224 through 234 Albany Street and which includes all or parts of lots numbered 19, 18 and a portion of a 20 foot right-of-way for sewer.

- 5.0 Rezone to Industry B-2 (with a Planned Unit Development Overlay-6) that area presently zoned Industry B, Industry A and Office 3, which is circumscribed by a line beginning at a point, said point being the intersection of the centerline of Erie Street and a line 100 feet southeast of and parallel to the southeastern sideline of Brookline Street, as shown on Assessor's Plat #96;
- 5.1 Thence proceeding in a southwesterly direction along a line 100 feet southeast of and parallel to the southeastern sideline of Brookline Street for approximately 365 feet to its intersection with the southwestern sideline of lot #109, on Assessor's Plat #96;
- 5.2 Thence turning and proceeding in a southeasterly direction along the southwestern sidelines of lots #109, 110, 102, 98 and its projection for approximately 325 feet to its intersection with the centerline of Sidney Street, as shown on Assessor's 96 and 66;
- 5.3 Thence turning and proceeding in a southwesterly direction along the centerline of Sidney Street for approximately 460 feet to the centerline of Putnam Avenue;
- 5.4 Thence turning and proceeding in a southeasterly direction along the centerline of Putnam Avenue for approximately 120 feet to its intersection with the northeasterly projection of a line 100 feet southeast of and parallel to the southeasterly sideline of Sidney Street;
- 5.5 Thence turning and proceeding in a southwesterly direction along a line 100 feet southeast of and parallel to the southeasterly sideline of Sidney Street and its projection for approximately 340 feet to its intersection with the centerline of Chestnut Street;
- 5.6 Thence turning and proceeding in a southeasterly direction along the centerline of Chestnut Street for approximately 5 feet to its intersection with the northeasterly projection of the northwesterly sideline of lot 45 on Assessor's Plat #65;
- 5.7 Thence turning and proceeding in a southwesterly direction along the northwesterly sideline of lot 45 and its projection and extension on Assessor's Plat #65 for approximately 250 feet to its intersection with the centerline of Henry Street;
- 5.8 Thence turning and proceeding in a westerly direction along the centerline of Henry Street for approximately 25 feet to its intersection with the northeasterly projection of the northwesterly sideline of lot 46 on Assessor's Plat #65;
- 5.9 Thence turning and proceeding in a southwesterly direction along the northwesterly sideline of lot 46 and its projection on Assessor's Plat #65 for approximately 140 feet to its intersection with the northerly sideline of said lot;

- 5.10 Thence turning and proceeding in a westerly direction along the northerly sideline of lot #46 for approximately 20 feet to its intersection with the westerly sideline of said lot;
- 5.11 Thence turning and proceeding in a southerly direction along the westerly sideline of lot #46 on Assessor's Plat #65 for approximately 24 feet to its intersection with the north-easterly sideline of lot 6 on Assessor's Plat #64;
- 5.12 Thence turning and proceeding in a northwesterly direction along the northeasterly sideline of lot 6 and its extension on Assessor's Plat #64 for approximately 630 feet to its intersection with the centerline of Brookline Street;
- 5.13 Thence turning and proceeding in a southwesterly direction along the centerline of Brookline Street and its extension for approximately 400 feet to its intersection with the northwesterly projection of the centerline of Memorial Drive as shown on Assessor's Plat #64;
- 5.14 Thence turning and proceeding in a southeasterly direction along the centerline of Memorial Drive and its projection for approximately 400 feet to its intersection with the northwesterly sideline of the Boston Albany Branch Railroad right-of-way;
- 5.15 Thence turning and proceeding in a northeasterly direction along the northwesterly sideline of the Boston-Albany Branch Railroad right-of-way for approximately 2045 feet to its intersection with the northeasterly sideline of lot 82 on Assessor's Plat #66;
- 5.16 Thence turning and proceeding in a northwesterly direction along the northeasterly sideline of lot 82 and its extension on Assessor's Plat #66 for approximately 275 feet to its intersection with the centerline of Anglim Street;
- 5.17 Thence turning and proceeding in a northerly direction along the centerline of Anglim Street for approximately 100 feet to its intersection with the centerline of Erie Street;
- 5.18 Thence turning and proceeding in a northwesterly direction along the centerline of Erie Street for approximately 780 feet to its intersection with a line 100 feet southeast of and parallel to the southeastern sideline of Brookline Street on Assessor's Plat #96, the point of origin.
- 5.00 Said area includes all or parts of the following parcels of land: (total land area is approximately 23 acres)
- 5.01 Premises located on Assessor's Plat #96:
Even numbers 80 through 100 Erie Street, numbers 51 through 90 Hamilton Street, odd numbers 179 through 201 Sidney Street, which includes all or parts of lots 126,127,124,117, 118,109,110,102,98.

5.02 Premises located on Assessor's Plat #66:

Even numbers 20 through 62 Erie Street, even numbers 178 through 244 Sidney Street, even numbers 604 through 610 Putnam Avenue, numbers 613 through 640 Putnam Avenue, numbers 1 through 24 Grove Avenue (private way), numbers 30 through 52 Allston Street, numbers 65 through 170 Waverly Street, Talbot Street, Anglim Street and Reardon Street (private way), 13 through 25 Chestnut Street, which includes all or parts of lots numbered, 101,82,81, 99,100,74,73,113,95,94,42,29,30,32,96,43,53,108,135,127, 126,125,121,122,123,11,10,124,106,105,1,14, and 12.

5.03 Premises located on Assessor's Plat #65:

Numbers 2 through 32 Henry, even numbers 2 through 20 Chestnut Street, which includes all or parts of lots numbered, 45,39, 46 and part of Waverly Street (private way).

5.04 Premises located on Assessor's Plat #64:

Even numbers 634 through 653 Memorial Drive, 400 Brookline Street, which includes all or parts of lot number 6.

- 6.0 Establish an overlay zone designated "Fort Washington Overlay District" over the existing district designations for the following described area of land:
 - 6.1 Beginning at a point, said point being the intersection of the northwesterly projection of a line 100 feet northwest of and parallel to the northwesterly sideline of lot 74 on Assessor's Plat #66 and the southwesterly projection of a line 100 feet southwest of and parallel to the southwesterly sideline of lot 74 on said plat;
 - 6.2 Thence proceeding in a northeasterly direction along a line 100 feet northwest of and parallel to the northwestern sideline of lot 74 and its projection and extension on Assessor's Plat #66 for approximately 380 feet to its intersection with the northwesterly projection of a line 100 feet northeast of and parallel to the northeast sideline of lot #74 on Assessor's Plat #66;
 - 6.3 Thence turning and proceeding in a southeasterly direction along a line 100 feet northeast of and parallel to the northeast sideline of lot 74 and its projection and extension on Assessor's Plat #66 and #61 for approximately 490 feet to its intersection with the easterly projection of a line 100 feet south of and parallel to the southerly sideline of lot #74 on said plat;
 - 6.4 Thence turning and proceeding in a westerly direction along a line 100 feet south of and parallel to the southerly sideline of lot 74 and its projection and extension on Assessor's Plat #66 and #61 for approximately 400 feet to its intersection with the southeasterly projection of a line 100 feet southwest of and parallel to the southwesterly sideline of lot #74 on Assessor's Plat #66 and #61;
 - 6.5 Thence turning and proceeding in a northwesterly direction along a line 100 feet southwest of and parallel to the southwesterly sideline of lot 74 and its projection and extension on Assessor's Plat #66 and #61 for approximately 380 feet to its intersection with the southwesterly projection of a line 100 feet northwest of and parallel to the northwest sideline of lot 74 on Assessor's Plat #66, the point of origin.
- 6.00 Said area includes all or parts of the following parcels of land: (total land area is approximately 4.5 acres)
 - 6.01 Premises located on Assessor's Plat #66:

Odd numbers 91 through 117 Waverly Street, all of Talbot Street and Reardon Street (private way) which includes all or parts of the following lots numbered 81,99,74,73,138 and a portion of the Boston Albany Branch Railroad right-of-way.
 - 6.02 Premises located on Assessor's Plat #61:

Odd numbers 269 through 289 Vassar Street, which includes all or parts of lots numbered 11,12,13,9 and a portion of the Boston Albany Branch Railroad right-of-way.

- 7.0 Rezone the Residence C-1 that area presently zoned Industry B and Industry A-1 which is circumscribed by a line beginning at a point, said point being the intersection of the centerline of Chestnut Street and northeasterly projection of southeasterly sideline of lot 44 on Assessor's Plat #65;
- 7.1 Thence proceeding in a southwesterly direction along the southeasterly sideline of lot 44 and its projection and extension for approximately 250 feet to its intersection with the centerline of Henry Street as shown on Assessor's Plat #65;
- 7.2 Thence turning and proceeding in a northwesterly direction along the centerline of Henry Street for approximately 25 feet to its intersection with the northerly projection of the easterly sideline of lot #47 on Assessor's Plat #65;
- 7.3 Thence turning and proceeding in a southwesterly direction along the easterly sideline of lot #47 and its projection for approximately 140 feet to its intersection with the southwesterly sideline of said lot on Assessor's Plat #65;
- 7.4 Thence turning and proceeding in a westerly direction along the southwesterly sideline of lot #47 on Assessor's Plat #65 for approximately 20 feet to its intersection with the easterly sideline of lot #51 on said plat;
- 7.5 Thence turning and proceeding in a southerly direction along the eastern sideline of lot #51 on Assessor's Plat #65 for approximately 24 feet to its intersection with the southwesterly sideline of said lot;
- 7.6 Thence turning and proceeding in a westerly and northwesterly direction along the southwesterly sideline of lot 51, 49 and its extension on Assessor's Plat #65 for approximately 650 feet to its intersection with the centerline of Brookline Street;
- 7.7 Thence turning and proceeding in a northeasterly direction along the centerline of Brookline Street for approximately 320 feet to its intersection with the centerline of Henry Street;
- 7.8 Thence turning and proceeding in a southeasterly and easterly direction along the centerline of Henry Street for approximately 430 feet to its intersection with the southwesterly projection of the centerline of Sidney Street;
- 7.9 Thence turning and proceeding in a northeasterly direction along the centerline of Sidney Street and its projection for approximately 310 feet to its intersection with the centerline of Chestnut Street;

7.10 Thence turning and proceeding in a southeasterly direction along the centerline of Chestnut Street for approximately 125 feet to its intersection with the northeasterly projection of the southeasterly sideline of lot 44 on Assessor's Plat #65, the point of origin.

7.00 Said area includes all of or parts of the following parcels of land: (total land area is approximately 3.6 acres)

7.01 Premises located on Assessor's Plat #65:

Even numbers 346 through 354 Brookline Street, even numbers 32 through 42 Henry Street, even numbers 276 through 300 Sidney Street, and number 38 Chestnut Street, which includes all or parts of the following lots numbered 44, 47, 51, 49 and 48.

0-5

FORT WASHINGTON ZONING
DISTRICT

Passed to be ordained

March 8, 1982

7 - 0 - 2

FORT WASHINGTON